

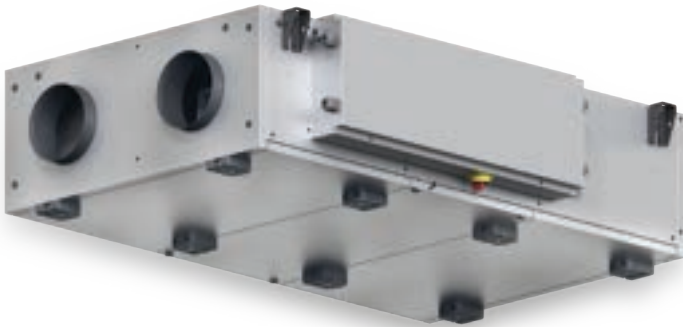

ENVU-PRO (650/1000/2000/2500/3500/4000)

Ceiling Type Heat Recovery Units



Assembly & Maintenance Guide



EN

Introduction.....	Page 1
Warnings & Safety Informations.....	Page 2
Check List.....	Page 4
Technical Specifications	Page 5
Description	Page 6
Unit Dimensions.....	Page 8
Installation	Page 10
Selection of Electrical Cable Cross-Section	Page 15
Maintenance	Page 16

INTRODUCTION

This document has been prepared and given to customer as a guide for easy installation&operation units manufactured by ENEKO A.Ş. The manual contains description of the unit, components and basic informations and recommendations for proper and fail free operation. Please read the instructions and warnings given in this manual before starting installation, operation and maintenance works and keep this manual near the unit, within easy reach of service personnel.



Any damage, failure or hazard occurred because of use except this purpose is beyond the responsibility of manufacturer.



For technical service and questions, please contact with following information.



+90 232 328 20 80 / 103-152



+90 536 713 10 00



www.eneko.com.tr



servis@eneko.com.tr

WARNINGS & SAFETY INFORMATION



PROHIBITED

- ◆ This unit has to be used under proper conditions according to its technical specification and design purpose. (Otherwise responsibility belongs to practitioner)
- ◆ Unauthorized personnel must not interfere in unit and/or must not use unoriginal spare parts. (Otherwise responsibility of failure that may occur belongs to practitioner)
- ◆ Do not install this product in a refrigerated warehouse, heated swimming pool or other location where temperature and humidity are significantly different. (Failure to heed this warning may result in electrical shock or malfunctioning.)
- ◆ Do not install this product where it will be directly exposed to rain. (Failure to heed this warning may result in electrical shock or malfunctioning.)
- ◆ Do not install this product in a location where acid, alkali or organic solvent vapors, paints or other toxic gases, gases containing corrosive components or high concentrations of oily smoke are present (Failure to heed this warning may result not only in malfunctioning but also fire, power leakage and electrical shock.)
- ◆ Do not use this product outside the range of its rated voltage and control capacity.



ATTENTION

- ◆ Install this product in an environment where the temperature ranges from $-5\text{ }^{\circ}\text{C}$ to $+40\text{ }^{\circ}\text{C}$ and the relative humidity is less than 60%. If condensation is expected to form, heat up the fresh outside air by a duct heater etc.
- ◆ Select an adequately sturdy position for installing the product and install it properly and securely.
- ◆ Use the designated electrical wires for the terminal board connections and connect the wires securely so that they will not be disconnected. (Failure to ensure proper connections may result in fire.)
- ◆ When passing metal ducts through wooden buildings clad with metal laths, wire laths or metal, these ducts must be installed in such a way that they will not make electrical contact with metal laths, wire laths or metal sheets. (Power leakage can cause ignition.)
- ◆ The outside ducts must be tilted at a gradient (1/30 or more) downwards toward the outdoor area from the main unit, and properly insulated. (The entry of rain water may cause power leaks, fire or damage to household property.)
- ◆ Gloves should be worn while installation. (Failure to heed this warning may result in injury.)
- ◆ A dedicated circuit breaker must be installed at the origin of mains power supply. This circuit breaker must be provided with a means for locking (lock and key).
- ◆ The body of the unit, room control panel and cables keep away the unit 3 m. distance.
- ◆ Do not open the service doors until the supply voltage has been disconnected at the isolation switch and the fans have stopped.

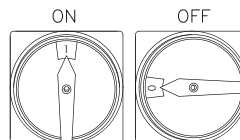

WARNINGS & SAFETY INFORMATION



ATTENTION

- ◆ The ENVU-PRO unit is not to be used to transport solid particles or in areas where there is a risk of explosive gases.
- ◆ If one or more of the inlets/outlets is not connected to a duct: Fit a protective net to the inlets/outlets with a maximum mesh width of 20 mm.



- ◆ This product must not be disassembled under any circumstances. Only authorized repair technicians are qualified to conduct disassembly and repairs. (Failure to heed this warning may result in fire, electrical shock or injury.)



- ◆ Connect the product properly to the ground. (Malfunctioning or power leaks can cause electrical shock.)



- ◆ An isolator switch having minimum contact gap of 3 mm in all poles must be provided as a means of disconnecting the power supply.

NOTE: The installations, which is not available for installation and operation manual, is out of guarantee.

CHECK LIST

In the event of unit failure and pre-commissioning checks to be made are determined as follows; after checking this information, please contact our company in case failure continues.

Controls

√

Make sure that the unit receives power and electrical grounding is made!

Make sure that the electricity cables are drawn from in the correct cross section! (Please check whether there is heating on cables or not.)

Please check whether the cables in unit control panel are shielded (shielded magnetic field) or not; make sure shielding is grounded. If not, please change them!

Make sure that fresh air and exhaust air filters are clean and they do not block the flow of air!

Make sure there is the connection of drainage on the unit, check any possible clogging in drainage line and clean if necessary!

Please check whether the diameter of the air duct connection of the unit and the diameter of the spigot are the same. If the duct connection is smaller, change it with the correct one.

Make sure the electrical connections of the unit are made as suggested on the unit and in this guide, check if there is incorrect connection.

Make sure during the installation of the unit there is enough space for the service and if there is not enough space, re-install again.

In extremely cold climate applications, frost may occur on the exchanger, apply electric heater in fresh air intake section of the unit to get the temperature to -5 °C and above.

After installing the unit, make sure that it does not create an abnormal sound or vibration, if there is, make sure that rubber pads are used.

Create a downward slope when connecting the drainage line. To effectively discharge water condensed in the exchanger and coils, connect a single 1" diameter drain hose to the drain outlet located on the side of the unit.

TECHNICAL SPECIFICATIONS

Product Model Identifier		ENVU-PRO650 LC/RC	ENVU-PRO1000 LC/RC	ENVU-PRO2000 LC/RC	ENVU-PRO2500 LC/RC	ENVU-PRO3500 LC/RC	ENVU-PRO4000 LM/RM
Nominal Airflow	m³/h	630	970	1840	2200	3120	3720
Thermal efficiency of HRS ¹	%	84,4	87,4	86,5	85,8	84,4	84,6
External pressure drop	PA	100	150	200	300	300	300
Unit voltage	(V/Hz/f)	230 / 50 / 1 ~				400 / 50 / 3 ~	
Unit power input	kW	0,37	0,48	1,04	1,5	2,24	2,66
Current	A	2,98	3,78	4,58	6,58	3,58	4,2
Sound pressure level @3m	Lpa	26	23,5	30,1	26,9	33,5	36
Supply air filter		ISO ePM1 >50% (F7)					
Exhaust air filter		ISO ePM10 >50% (M5)					
Duct connections		Round		Rectangular			
On/Off heater electrical		3,00 kW	5,00 kW	8,00 kW	11,00 kW	14,00 kW	18,00 kW
		One step					
Proportional Heater Electrical (Low Capacity)				4,00 kW	5,50 kW	7,00 kW	9,00 kW
Proportional Heater Electrical (High Capacity)		3,00 kW	5,00 kW	8,00 kW	11,00 kW	14,00 kW	18,00 kW
Internet adress for pre-/dis-assembly instructions		www.eneko.com.tr					

1*Wet efficiency refered to nominal airflow, outdoor (-5°C/80% RH) and indoor conditions (20°C/50%RH).

Construction of the ENVU-PRO unit

The drawings below shows an overview of the Envu-pro unit construction. First two drawings show a Envu-pro unit with circular inlets / outlets. Last four drawings show a Envu-pro unit with rectangular.

ENVU-PRO 650/1000

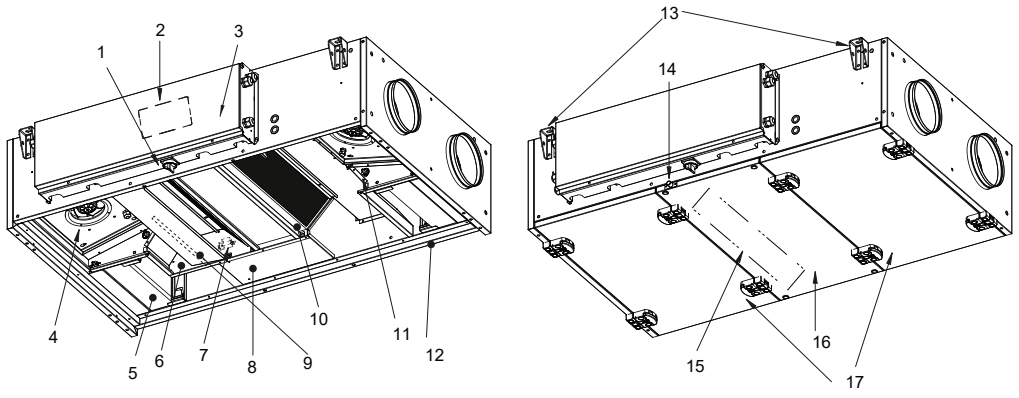

ENVU-PRO 2000/2500/3500

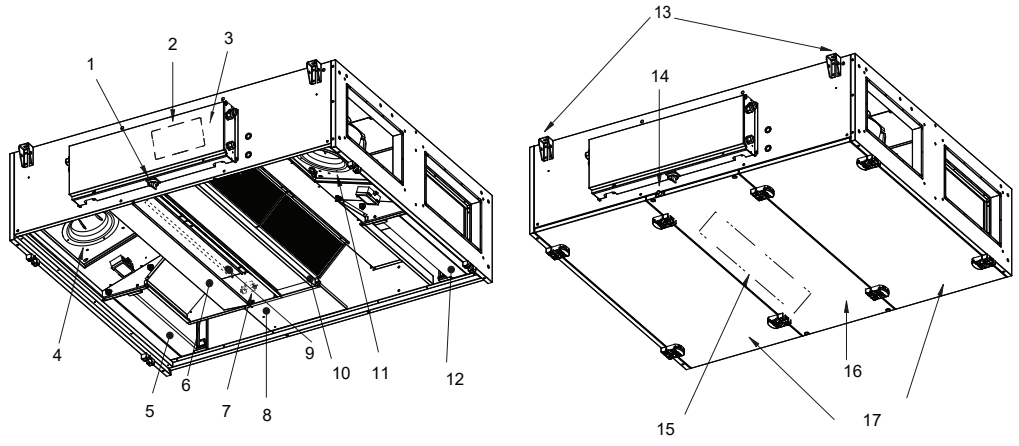

ENVU-PRO 4000

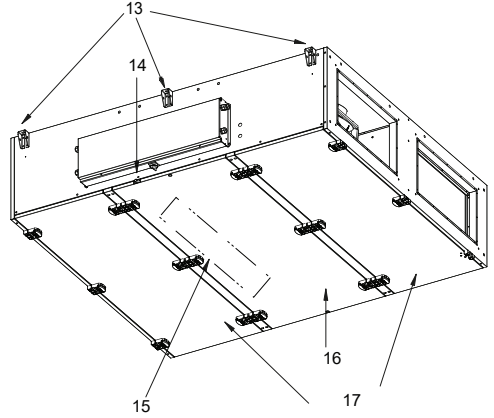
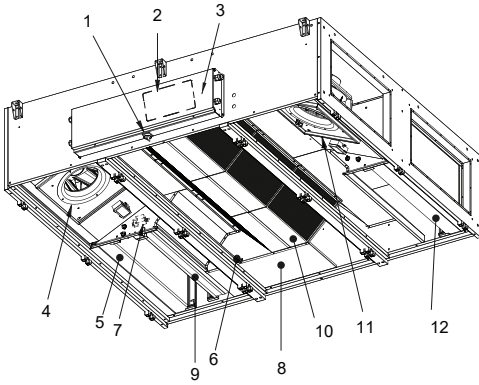

Pos.	Part	Function
1	Isolation Switch	Connects/disconnects current.
2	Control Panel	Control system.
3	Connection box	Connection of accessories and power supply.
4	Exhaust Air Fan	Removes the stale air.
5	Supply Air Filter	Filters the supply air.
6	Additional Condensation Tray (Optional)	Collects condensed water and drains it from the counterflow heat exchanger to the condensation tray.
7	Bypass Motor	Opens/closes bypass damper.
8	Bypass Duct	Directs air around the counterflow heat exchanger.
9	Bypass Damper	Opens/closes bypass duct and heat exchanger.
10	Counterflow Heat Exchanger	Enables heat exchange between stale and fresh air.
11	Supply Air Fan	Blows fresh air into the room.
12	Exhaust Air Filter	Filters the exhaust air.
13	Suspension Clamps	Clamps for fitting the unit to the ceiling (2 or 3 at each side depending on unit size).
14	Condensation Outlet Pipe	Transfers condensed water from the condensation tray. External condensation outlet is connected to it via siphon.
15	Condensation Tray	Collects condensed water and drains it from the counterflow heat exchanger to the condensation outlet.
16	Middle Panel/Door	Counterflow heat exchanger cover for inspection and service.
17	Door	Sliding doors/hinged doors for inspection and service (Hinged doors can open left or right side, depending on user's as choice).

UNIT DIMENSIONS

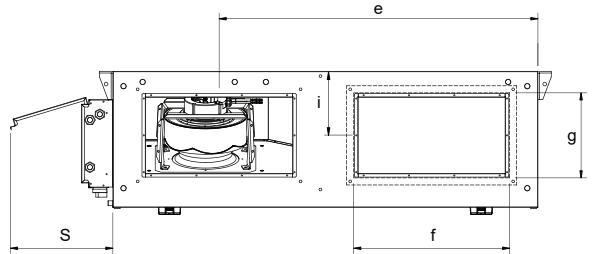
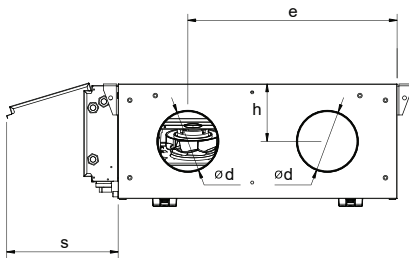
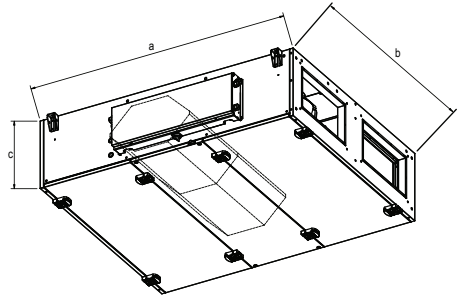
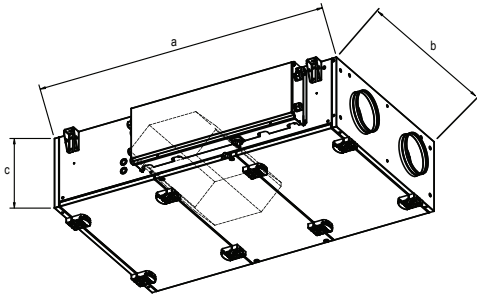

	ENVU-PRO650 LC/RC	ENVU-PRO1000 LC/RC	ENVU-PRO2000 LC/RC	ENVU-PRO2500 LC/RC	ENVU-PRO3500 LC/RC	ENVU-PRO4000 LM/RM
a	900	1150	1500	1650	1650	1970
b	1500	1600	1800	2000	2100	2250
c	370	400	480	565	580	580
Ød	200	250	-	-	-	-
e	675	863	1125	1238	1238	1478
f	-	-	517	567	567	717
g	-	-	267	367	367	367
h	185	200	267	367	367	367
i	-	-	226	283	290	290
s	370	370	300	400	400	400
Unit weight	125	164	230	286	320	370

* All measurement values are mm.

* The gaps of the maintenance area values are specified as "S" on the table. The dimensions on page 11 regarding the door opening distance should be considered.

* Unit weight is kg.

UNIT DIMENSIONS

Top view

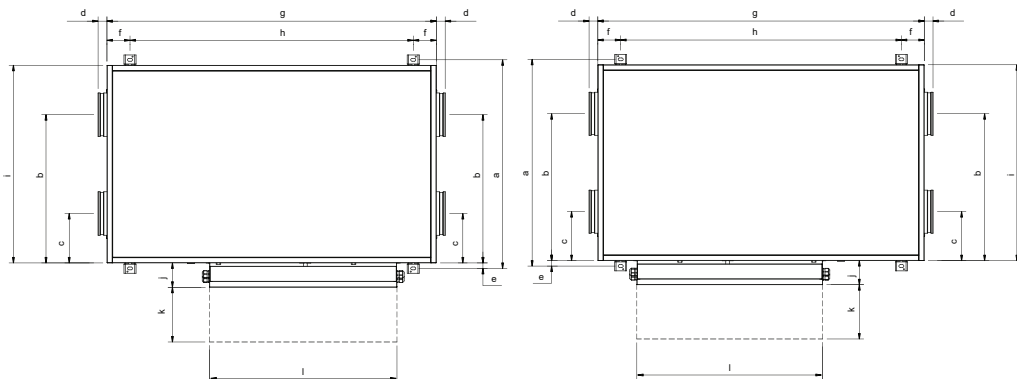

Model	a	b	c	d	e	f	g	h	i	j	k	l
ENVU-PRO650LC/RC	950	675	225	40	25	105	1500	1290	900	110	260	852
ENVU-PRO1000LC/RC	1200	863	288	60	25	105	1600	1390	1150	110	260	852

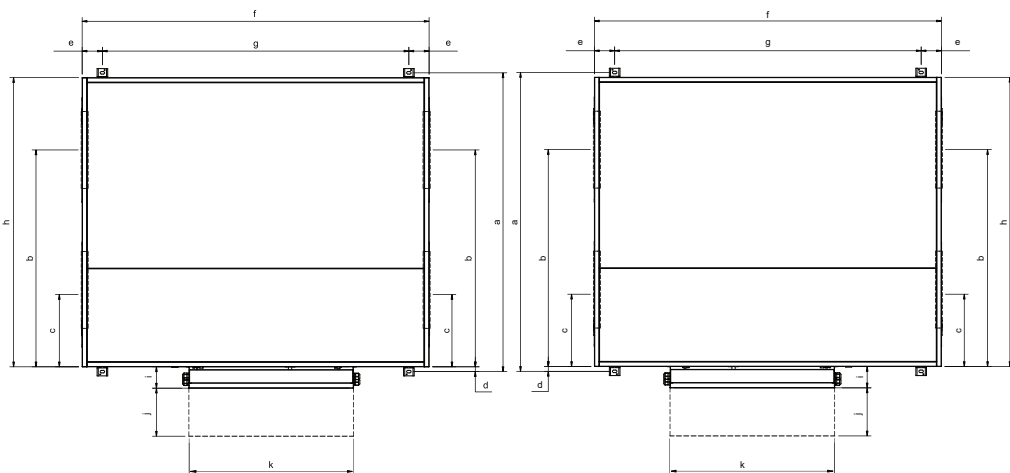

Model	a	b	c	d	e	f	g	h	i	j	k
ENVU-PRO 2000LC/RC	1550	1125	375	25	105	1800	1590	1500	110	260	852
ENVU-PRO 2500LC/RC	1700	1238	413	25	105	2000	1790	1650	110	260	927
ENVU-PRO 3500LC/RC	1700	1238	413	25	105	2100	1890	1650	110	260	927
ENVU-PRO 4000LC/RC	2020	1478	493	25	105	2250	2040	1970	110	260	1002

Positioning

The ENVU-PRO unit is designed for indoor fitting. The unit may be positioned with the side opposite the connection box up against a rear wall.

Space requirements

Envu-pro with hinged doors (standard)

The cabinet has three hinged doors. The drawing below indicates how much space is needed for opening the doors and servicing the unit, i.e. changing filters, cleaning, servicing, etc.

Opening outside,

ENVU-PRO 650/1000

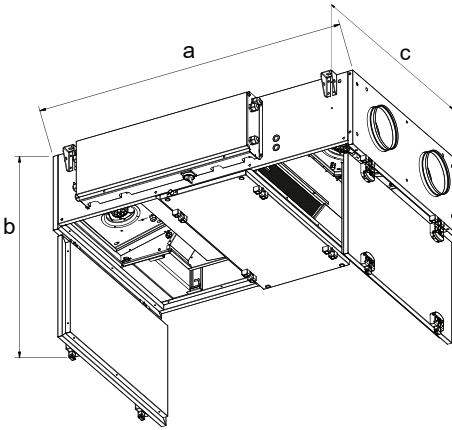

Opening inside,

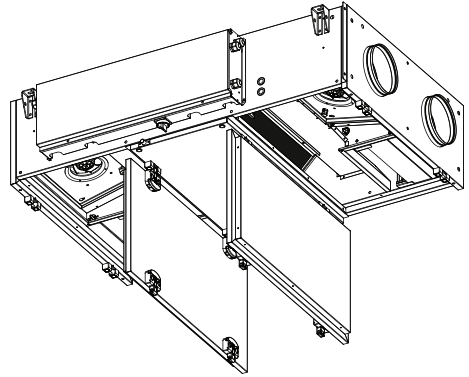

ENVU-PRO 2000/2500/3500

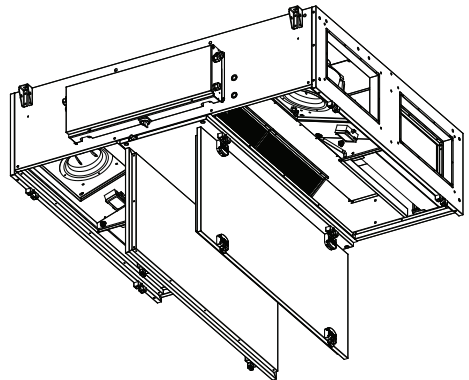
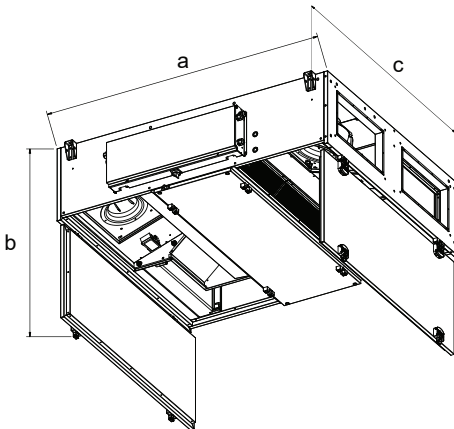

ENVU-PRO 4000

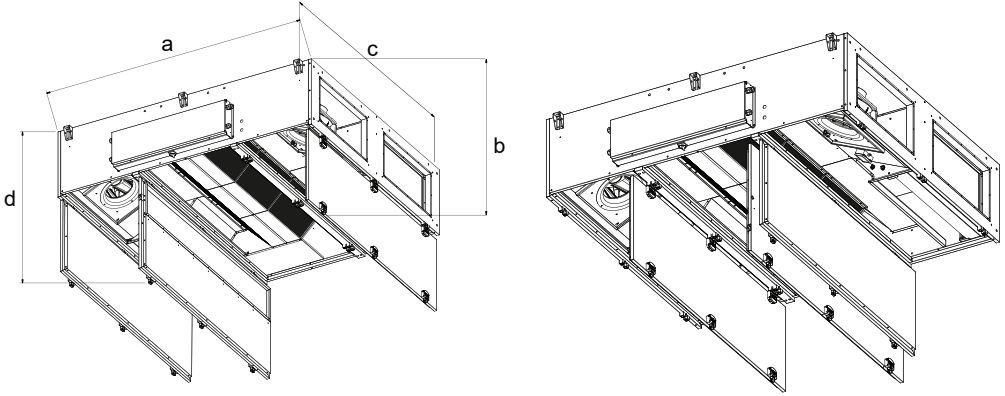

Model	a	b	c	d
ENVU-PRO 650 LC / RC	1500	940	994	-
ENVU-PRO 1000 LC / RC	1600	1000	1244	-
ENVU-PRO 2000 LC / RC	1800	1160	1594	-
ENVU-PRO 2500 LC / RC	2000	1300	1744	-
ENVU-PRO 3500 LC / RC	2100	1365	1744	-
ENVU-PRO 4000 LM / RM	2250	1275	2064	1450

Envu-pro with sliding rails (accessory)

The cabinet has 2/3 doors which can be individually released and slide sideways allow filter change and cleaning.

Note: Sliding rail accessory is optional.

ENVU-PRO 650/1000

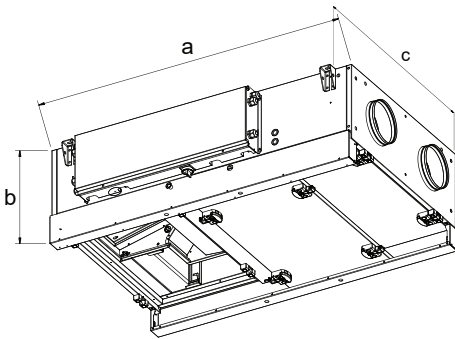

ENVU-PRO 2000/3500/4000

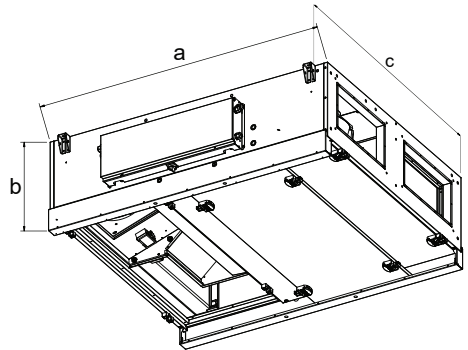

Note: For all units in ENVU-PRO Range, dimensions are identical for both left and right units.

INSTALLATION

Model	a	b	c
ENVU-PRO 650 LC / RC	1500	475	994
ENVU-PRO 1000 LC / RC	1600	505	1244
ENVU-PRO 2000 LC / RC	1800	585	1594
ENVU-PRO 2500 LC / RC	2000	670	1744
ENVU-PRO 3500 LC / RC	2100	685	1744
ENVU-PRO 4000 LM / RM	2250	685	2064

Preparing The Sling Bolts

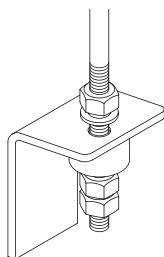

Note: Rubber suspension chocks provided inside the unit's package need to be used below the suspension clamps as shown in the given figure above. Same action needs to be taken with the unit accessories which have suspension clamps.

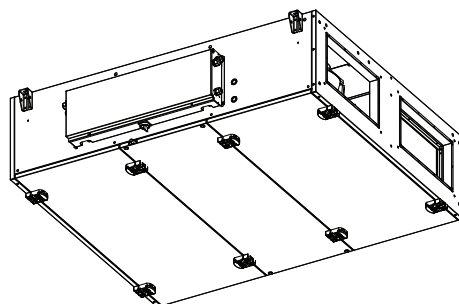
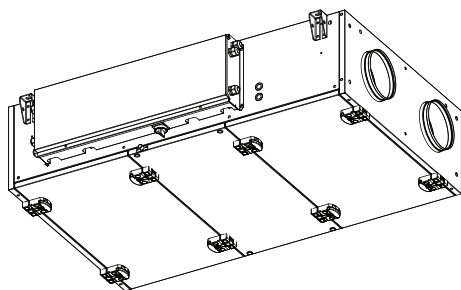

The table below shows the unit's dimensions, and is intended to indicate how large an opening has to be for the unit to pass through:

Note: +100 mm for fitting through passages (tolerance).

For all units in Envu-pro Range, dimensions are identical for both left and right units.

Model	Length	Width	Height
ENVU-PRO 650 LC / RC	1580	1010	395
ENVU-PRO 1000 LC / RC	1720	1260	425
ENVU-PRO 2000 LC / RC	1800	1610	505
ENVU-PRO 2500 LC / RC	2000	1760	590
ENVU-PRO 3500 LC / RC	2100	1760	605
ENVU-PRO 4000 LM / RM	2250	2080	605

INSTALLATION

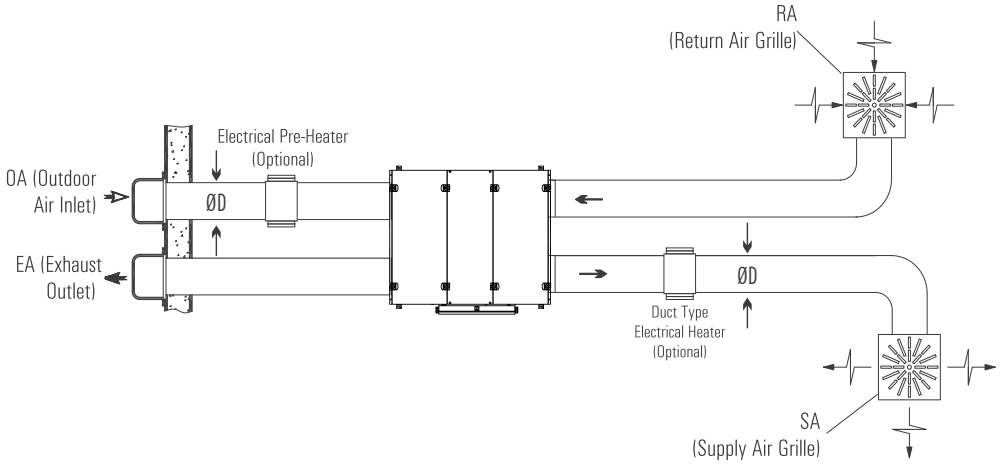

*Drain pipe must be installed

*The device direction is left
*View from bottom

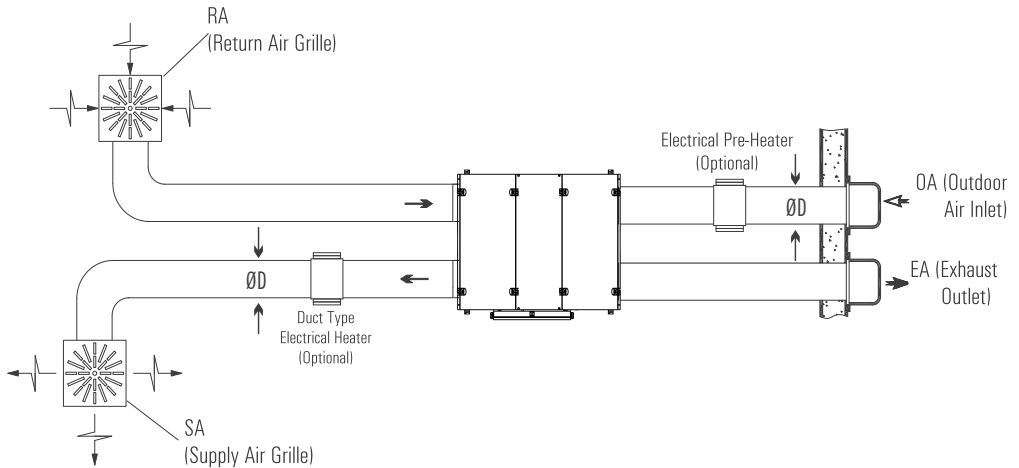

*Drain pipe must be installed

*The device direction is right
*View from bottom

INSTALLATION

! CAUTION

Check these warnings before installation.

Extremely Sharp Bends



Multiple Bends

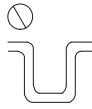

Bends right next to the outlet



Extreme Reduction in the diameter of the connected ducts

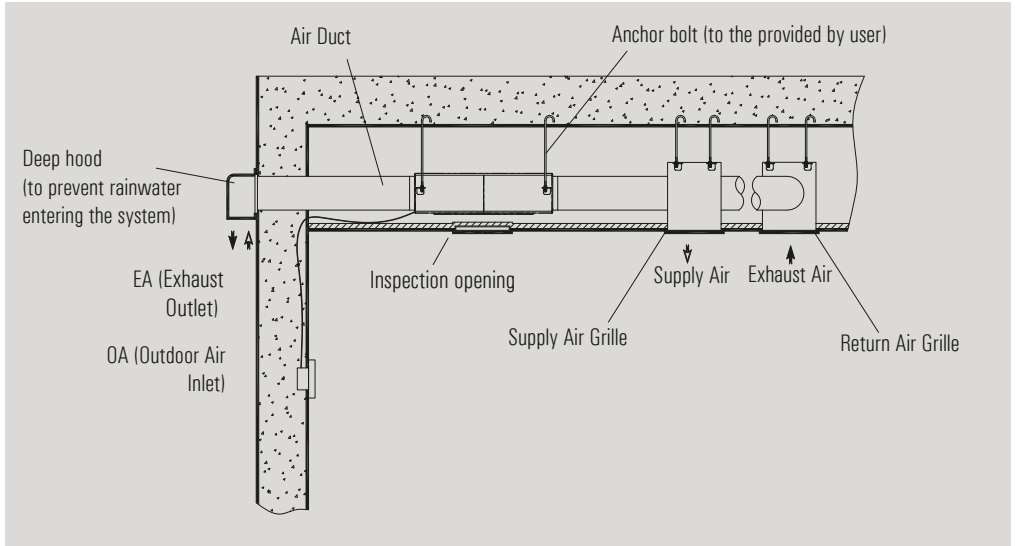
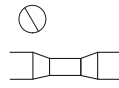

SELECTION OF ELECTRICAL CABLE CROSS-SECTION

Unit Model	Unit Voltage (V)	Unit Power Input (kW)	Current (A)	Fuse (A)	Cable Cross-Section (mm ²) for 50M and PF=0.8
ENVU-PRO 650 LC / RC	230	0.37	2.98	2x4	1
ENVU-PRO 1000 LC / RC	230	0.48	3.78	2x6	1
ENVU-PRO 2000 LC / RC	230	1.04	4.58	2x6	2.5
ENVU-PRO 2500 LC / RC	230	1.50	6.58	2x10	4
ENVU-PRO 3500 LC / RC	400	2.24	3.58	3x4	2.5
ENVU-PRO 4000 LM / RM	400	2.66	4.20	3x6	2.5

The data in the table shows the maximum power/current values. Please check unit label for updated values.

Cable Cross-Section Formulas

$$1 \quad I_{\text{current}} = \frac{P}{U \cdot \text{Cos}\phi}$$

$$I_{\text{cable}} > I_{\text{current}}$$

$$2 \quad \%e = \frac{100 \cdot P \cdot L}{k \cdot S \cdot U^2}, \quad S = \frac{100 \cdot P \cdot L}{k \cdot \%e \cdot U^2}$$

$$\%e = \%3$$

3

$$I_{\text{cable}} > I_{\text{fuse}} \geq I_{\text{current}}$$

$$\text{Cable Cross-Section } S = \text{Max}(S1, S2, S3, 1.5\text{mm}^2)$$

P : Power

I : Current

U : Voltage

S : Conductor cross section

k : Conductor coefficient

L : Conductor length

%e: The voltage drop

Example of Cable Cross-Section Calculation

P : 1 kW

L : 50m

U : 230V

%e : %3

PF : Cosφ : 0.8

k : 56m / Ω

$$1 \quad I_{\text{current}} = \frac{1000 \text{ W}}{230 \cdot 0,8} = 5.43 \text{ A}$$

The cable will be used, is selected from the cable cross-section table so that the equivalent ampere value in the table should be higher than calculated "I_{current}" value.

$$S1 = 1.5 \text{ mm}^2$$

2

$$\%e = \%3$$

$$S = \frac{100 \cdot 1000 \cdot 50}{56.3 \cdot 230^2} = 0.56 \text{ mm}^2$$

$$S2 \geq 0.56 \text{ mm}^2 \geq 0.75 \text{ mm}^2$$

$$S2 = 0.75 \text{ mm}^2$$

3

$$I_{\text{cable}} > I_{\text{fuse}} \geq I_{\text{current}}$$

$$I_{\text{cable}} > 10A \geq 5.43A$$

"I_{fuse}" which will be higher than "I_{current}", is selected.

The cable will be used, is selected from the cable cross-section table so that the equivalent ampere value in the table should be higher than selected "I_{fuse}" value.

$$I_{\text{cable}} = 24A$$

$$S3 = 1.5 \text{ mm}^2$$

$$\text{Cable cross-section } S = \text{Max}(S1, S2, S3, 1.5 \text{ mm}^2)$$

$$S = \text{Max}(1.5, 0.75, 1.5, 1.5)$$

$$S = 1.5 \text{ mm}^2$$

How to change filters

The Envu-pro unit doors must be opened to allow servicing and cleaning. Disconnect the power at the isolation switch before opening the doors.

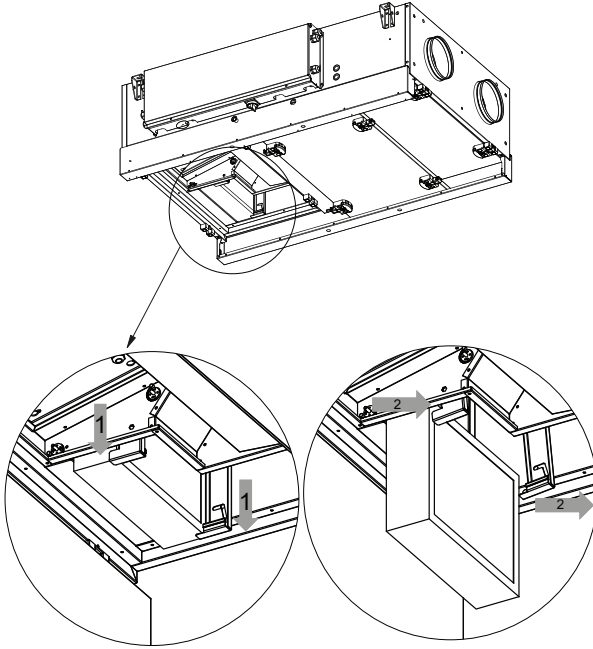

1. Disconnect power to the unit.
2. Open the unit doors.
3. Pull filter clamps in downward (Arrow 1) direction. Then, push filter clamps in sideways (Arrow 2) direction. Filter is now free and can be removed in downwards (Arrow 1) direction.
4. Put the filter in a plastic bag and seal it tightly. Arrange for disposal according to local waste disposal regulations.

Note: When a filter alarm is received, the filter should be changed. If the filter does not give an alarm, it should still be changed every max 6 months.

How to service the motor

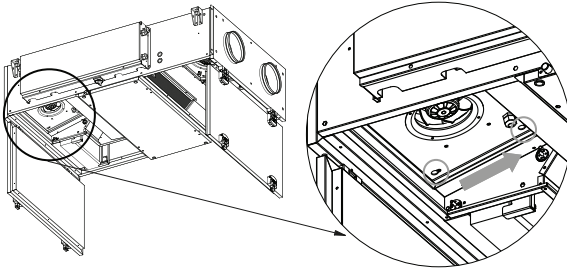

1. Disconnect power to the unit.
2. Open the unit doors.
3. Detach sockets and the pressure hose from the pressure transmitter.
4. Loosen the four screws on the corners as shown with circles in the drawing. Then, slide the fan in the arrow's direction to remove the fan.
5. The motor section can now be removed.
6. Pull the motor downwards.
7. Clean the impeller:
 - by vacuum cleaning.
 - by wiping with a cloth dipped in soap and water and well wrung out.
- Note:** Clean all blades on the fan impeller carefully to avoid disrupting the balance.
8. After cleaning, check Envu-pro unit whether it operates without vibration.

How to service the bypass damper

Disconnect power at the isolation switch before opening the doors.

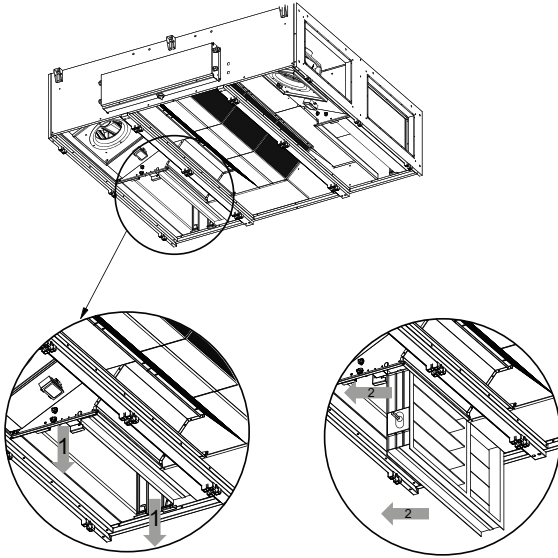

1. Disconnect power to the unit.
2. Open the unit doors.
3. Detach the bypass damper motor socket.
4. Pull damper clamps in downward (Arrow 1) direction. Then, push damper clamps in sideway (Arrow 2) direction. Damper is now free and can be removed in downwards (Arrow 1) direction.
5. The bypass damper section can now be removed.

Note 1: Instructions given in the table are not valid for Envu-pro 650/1000/2000 models. In the 650/1000/2000 series models, only the damper motor is being removed. For all Envu-pro 2500/3500/4000 units, bypass damper service instructions given in the table are identical.

How to remove the counterflow heat exchangers

Note: The counter flow heat exchanger fins can easily be damaged - avoid contact with the fins.

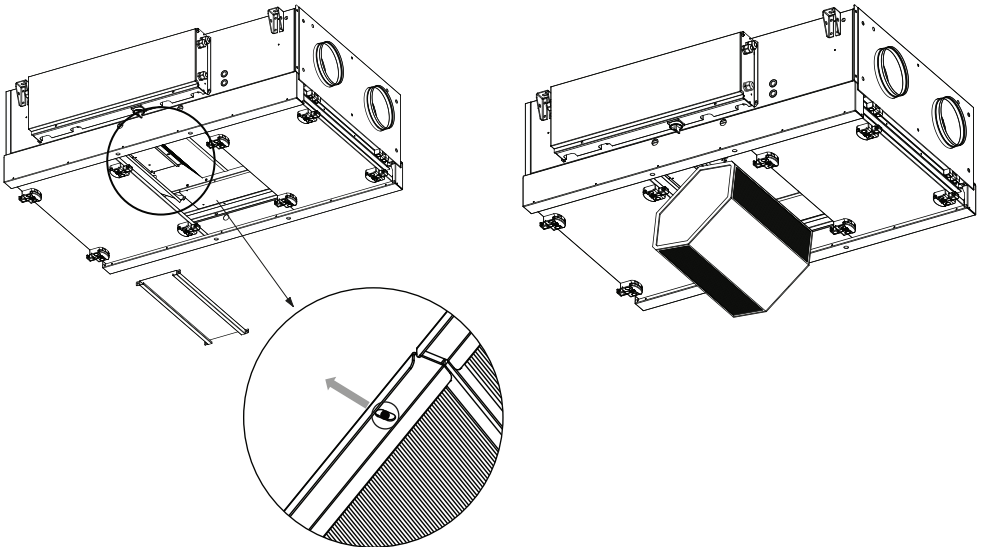

1. Disconnect power to the unit.
2. Open the unit doors.
3. Unscrew 2 screws which holds the additional condensation tray and move the tray downwards.
4. Unscrew 4 screws which holds the additional sheet metal part and remove it.
5. Loosen the rail screws shown with a circle and slide the rails sideways as shown with an arrow to remove the heat exchanger. Remember to hold the heat exchanger from the bottom.
6. The heat exchanger is now free and can be removed. Remove the heat exchanger by rotating to fit it through the opening between doors as shown in the drawing.

Step	Action
1	Clean the exchanger by flushing with warm water (a high-pressure cleaner can be used). Max. water temperature: 90 °C.
2	Check seal and replace if it is worn or deformed.
3	Be careful to avoid damages to heat exchanger fins.

Condensation drain

Risk of frost



Drain the condensation outlet into a floor gully or similar. The condensation outlet must be fitted with a water trap. See below.



Where there is a risk of frost: Insulate the condensation outlet and protect it against frost - if necessary, using a heating cable.

Water trap

The following drawing shows an example of how the drain from the condensation could be made.

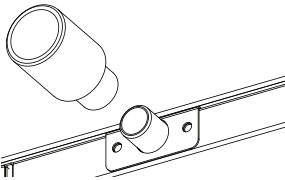

Note: Condensation drainage siphon adaptor provided inside the unit package needs to be assembled to drainage outlet before assembling the siphon. Same action needs to be taken with "changeover coil box" accessory.

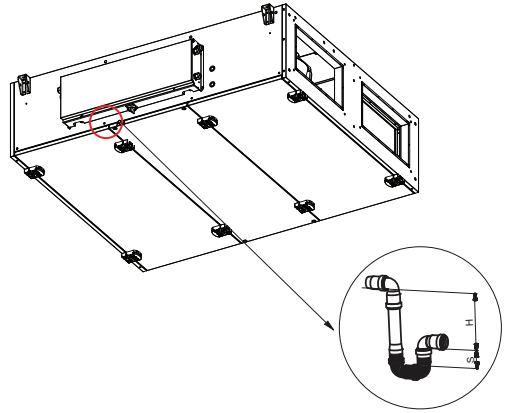
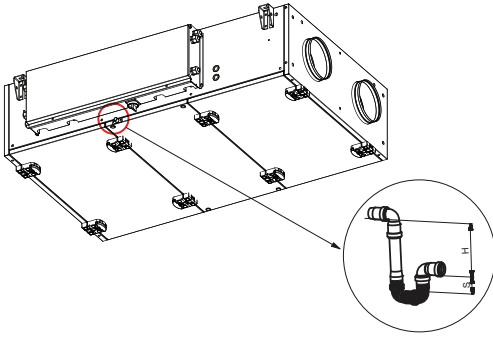

ENVU-PRO Unit Model	S (mm)	H (mm)
ENVU-PRO 650 LC / RC	20	33
ENVU-PRO 1000 LC / RC	25	41
ENVU-PRO 2000 LC / RC	25	42
ENVU-PRO 2500 LC / RC	29	48
ENVU-PRO 3500 LC / RC	35	58
ENVU-PRO 4000 LM / RM	34	57

Note 1: The condensation outlet must be dismantled before the middle panel/door can be opened. For this reason, the pipe layout must allow the drain tube to be disconnected.

Dimensions indicate the minimum required values.

Note 2: Check that the unit hangs horizontally or slopes towards the condensation drain. Clean and vacuum clean the Envu-pro unit to remove metal shavings, etc.

Maintenance with sliding rails (accessory)

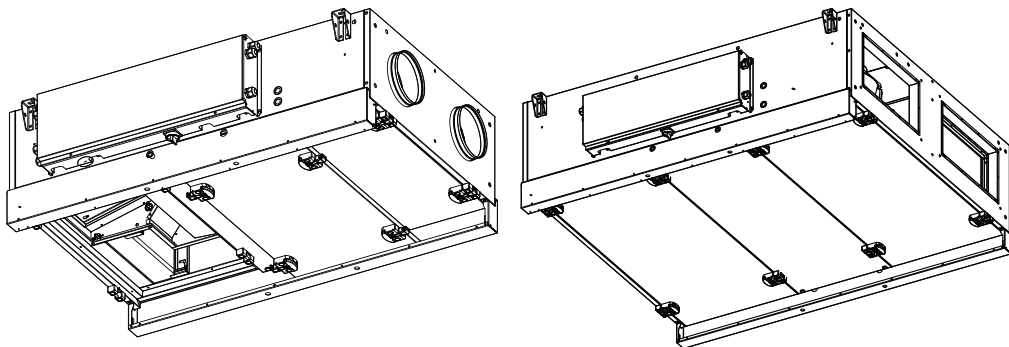

Filtering changes, motor cleaning, testing etc. Follow the steps below.

1. First dismount one door
2. Place it on the sliding rail and slide it under the other door
3. Carry out servicing and remount the door
4. Repeat with the other door.

Follow the steps below for heat exchanger service.

1. First dismount one door
2. Place it on the sliding rail and slide it under the other door
3. Carry out servicing and remount the door
4. Repeat with the other door.

How to connect the heating coil to the unit (accessory)

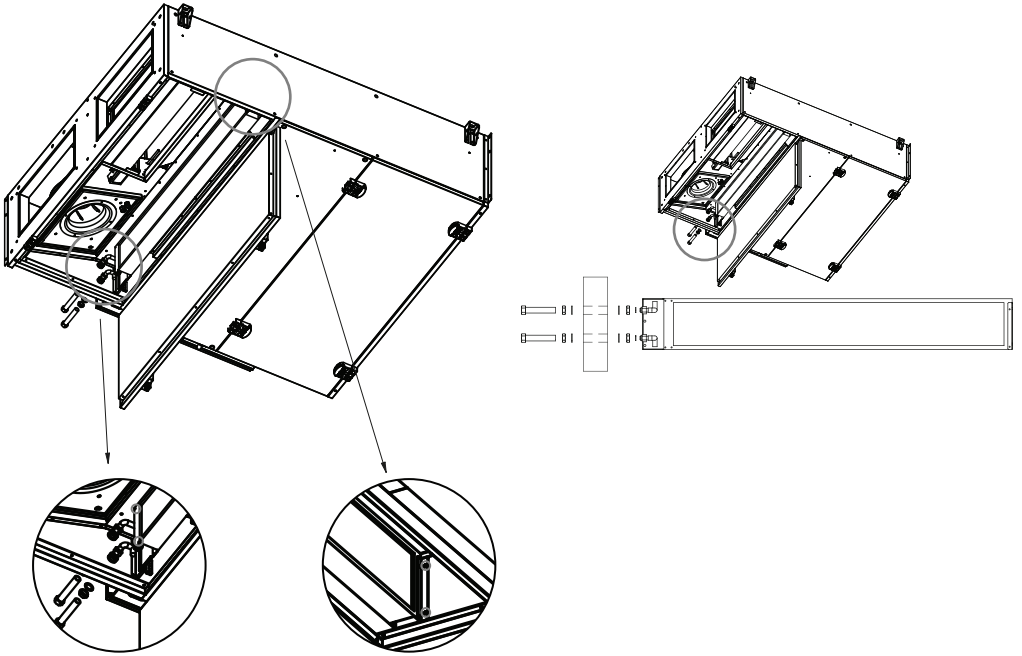

1. Switch off the power supply to the unit with the isolation switch. **Note:** If there is any electrical heater connected to the unit, switch off power to the electrical heater with the isolation switch on the heater.
2. Open the heating coil package.
3. Loosen the connection bolts on the unit to assemble the heating coil inside. Place the heating coil inside ventilation unit.
4. Tighten bolts on the unit to assemble the heating coil. For the holes given in the second figure, use screws to assemble the heating coil.
5. Connect the pipes provided inside the heating coil package to the heating coil pipes. Use the rubber gaskets provided inside the package.
6. Connect the piping to the heating coil pipes. Use a double wrench while connecting piping to the changeover coil box to prevent any damage to the pipes.
- Note:** Remember to put anti-freeze inside the coil. Attach the freezing temperature sensor provided inside the coil box package to the water outlet pipe of the changeover coil box. Use plastic clamps to attach the sensor to the pipe.
7. Connect the temperature sensor to the ventilation unit e-box.
8. Connect the 3-way valve provided inside the heating coil package to the heating coil.
9. Assemble the 3-way valve actuator provided inside the heating coil package to the 3-way valve.
10. Connect the 3-way valve actuator to the ventilation unit e-box with the communication cable provided inside the heating coil package.



Warranty Certificate

- * If the unit is used according to the instructions given in user manual and interfered in only authorized technical service that we authorize about any maintenance and repair reasons, all spare parts will be under warranty for 2 years against material, labor and production faults except motor components.
- * Identifying of parts replaced and determining troubleshooting technical procedure applied, will belong to our company.
- * After ex-works of goods, all faults during loading, unloading and shipment will be out of guarantee. If a falsify has been made on documents or any falsify and changing have been made on serial number, goods will be out of guarantee.

Terms of Guarantee

1. Guarantee period is 2 years as from the time of delivery.
2. All spare parts except motor components are under warranty.
3. If the goods break down during guarantee period, the time spent for maintenance will be added to guarantee period. Maintenance period is 30 days at most. 30 days begin with the notice to a service station. If there is no service station, 30 days begin with the notice to the seller, dealer, agency, agent, importer or manufacturer of the goods.
4. If production fault occurs during guarantee period; the cost of new spare part and labor will not be claimed from the customer.
5. If a fault occurs because of not using or assembling according to the instructions given in user manual, goods will be out of guarantee.

UNIT TYPE

SERIAL NO

ENEKO Havalandırma ve Isı Ekonomisi
Sistem Teknolojileri Makina San. ve Tic. A.Ş.
10049 Sokak No: 04 AOSB Cıgılı/İZMİR
Tel: 0.232.328 20 80
Web Address: www.eneko.com.tr

SIGNATURE:



www.eneko.com.tr

ISTANBUL

 Cevizli District, Zuhul Avenue, Fusun Street, Ritim Istanbul
A5 Block Floor: 25 No: 137, 34846 Maltepe/Istanbul - TURKEY

 +90 216 455 29 60 / +90 216 455 29 61

 +90 216 455 29 62

 satis@eneko.com.tr

IZMIR

 10049 Street No: 4 I.A.O.S.B.
Cigli/Izmir - TURKEY

 +90 232 328 20 80

 +90 232 328 20 22

 info@eneko.com.tr





REGIN (Corrigo Ardo)



Automation User Manual



EN

Introduction	Page 1
Warnings & Safety Informations	Page 2
Display & Buttons	Page 3
Menu Structure & Features	Page 7
Functions	Page 13
Accessories	Page 15
Communications	Page 18

INTRODUCTION

This Automation User Manual has been prepared for the correct installation and use of the control systems of the units manufactured by ENeko A.Ş. The Automation user manual contains description of the unit, components and basic informations and recommendations for proper and fail free operation. Please read the instructions and warnings given in this manual before starting installation, operation and maintenance works and keep this manual near the unit, within easy reach of service personnel.



Any damage, failure or hazard occurred because of use except this purpose is beyond the responsibility of manufacturer.



For technical service and questions, please contact with following information.



+90 232 328 20 80 / 103-152



+90 536 713 10 00



www.eneko.com.tr



servis@eneko.com.tr

WARNINGS & SAFETY INFORMATION



PROHIBITED

- ◆ This unit has to be used under proper conditions according to its technical specification and design purpose. (Otherwise responsibility belongs to practitioner)
- ◆ Unauthorized personnel must not interfere in unit and/or must not use unoriginal spare parts. (Otherwise responsibility of failure that may occur belongs to practitioner)
- ◆ Do not use this control system other than the operating conditions specified in the installation and maintenance manual of the device. Do not use this control system in environments exposed to rain. (Otherwise, it may cause electric shocks or malfunction of the device)
- ◆ Do not use this unit in acid, alkali or organic solvent vapors, paint or other toxic gases, gases containing corrosive substances, or in environments with high concentrations of oily smoke.
Failure to heed this warning may result not only in the control system malfunctioning, but also in fire, electric leakage, and electric shock.



ATTENTION

- ◆ The relevant connection diagram is on the cover of the panel.
- ◆ Use the designated electrical wires for the terminal board connections and connect the wires securely so that they will not be disconnected. (Failure to ensure proper connections may result in fire.)
- ◆ In the ducts passing through the building, in the parts of the ducts that are in contact with the building construction, make sure that the ducts are not in any electrical contact with the metal parts. (Electric leaks can cause fire and explosion.)
- ◆ Gloves should be worn while installation. (Failure to heed this warning may result in injury.)
- ◆ A dedicated circuit breaker must be installed at the origin of mains power supply. This circuit breaker must be provided with a means for locking (lock and key).
- ◆ The unit, the room control panel and cables must be at least 3 meters away from equipment or cables that create a high electromagnetic field. (Otherwise it may cause the device not to work.)
- ◆ During the replacement of spare parts, the layout of the panel must be maintained and the part must be assembled as it came from the factory.



- ◆ This product must not be disassembled under any circumstances. Only authorized repair technicians are qualified to conduct disassembly and repairs.
(Failure to heed this warning may result in fire, electrical shock or injury.)



- ◆ Connect the product properly to the ground. (Malfunctioning or power leaks can cause electrical shock.)



- ◆ An isolator switch having minimum contact gap of 3 mm in all poles must be provided as a means of disconnecting the power supply.

NOTE: The installations, which is not available for installation and otomation manual, is out of guarantee.

DISPLAY & BUTTONS



Standard Panel



PLC with display

Technical Data	Panel	PLC
Protection class	IP30	IP20
Ambient temperature	5...40°C	0...50 °C
Storage temperature	-40... +50°C	-20... +70 °C
Ambient humidity	5...95 % RH	Max 95 % RH
Port type (or Connection type)	26AWG /4P4C quick connection	RS485 / Ethernet
Communication speed	--	9600 baud (1200...76800 baud)
Supported protocols	--	EXoline-TCP / Modbus-TCP / BACnet/IP

The display has 4 rows of 20 characters each. It has background illumination. The illumination is normally off, but is activated as soon as a button is pressed. The illumination will be turned off again after a period of inactivity.

Leds



Symbol	Colour	Function
	Flashing red	There are one or more unacknowledged alarms.
	Fixed red	There are one or more remaining acknowledged alarms.
	Flashing yellow	You are in a dialog box where it is possible to switch to change mode. A quick blinking (2 times/s) indicates that the parameter can be changed using the current access level. A slower blinking (1 time/s) indicates that a higher access level is required to change the parameter.
	Fixed yellow	You are in change mode.

Status indication

Designation	Colour	Description
P1 RxTx	Yellow/Green	Port 1, receiving/transmitting
P2 RxTx	Yellow/Green	Port 2, receiving/transmitting
TCP/IP (...W models)	Yellow/Green	Green: Connected to other network equipment Blinking green: Network traffic Blinking yellow: For identifying (for example when marking the unit in Application tool)
P/B (Power/Battery)	Yellow/Green	Power on / Battery error

DISPLAY & BUTTONS

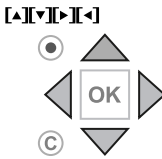
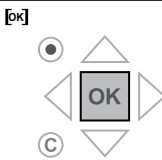
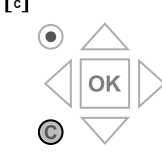
Status indication

Buttons	Functions	Functions in Alarm mode
	<p>Navigation buttons:</p> <ul style="list-style-type: none"> ▲ Navigate upwards. ▼ Navigate downwards. ► Navigate to the right. ◄ Navigate to the left. <p>In change mode:</p> <ul style="list-style-type: none"> ◄ Move cursor to the left. ► Move cursor to the right. ▲ Increase the value by 1. ▼ Decrease the value by 1. ▲ and ▼ Scroll among the texts when there are several alternatives 	<ul style="list-style-type: none"> ▲ Navigate up in the alarm stack. ▼ Navigate down in the alarm stack. ◄ Exit alarm display mode.
	<ul style="list-style-type: none"> ✓ Enter change mode. ✓ Confirm a new value in change mode. An input must be confirmed with this button in order to change the value in the controller. When a value has been confirmed, the cursor will move to the next editable value in the current box. 	<ul style="list-style-type: none"> ✓ A menu with all actions that are available for the current alarm is displayed.
	<ul style="list-style-type: none"> ✓ Enter change mode and erase the value in the display. ✓ Erase the sign at the cursor. ✓ When the current value is completely empty, the edit mode is cancelled and the cursor will move to the next value that will also be erased in the window. ✓ Undo (erase) the input 	
	<ul style="list-style-type: none"> ✓ Enter alarm display mode. 	<ul style="list-style-type: none"> ✓ Browse among alarms in alarm display mode.

Navigating the menus

The appearance of the start display may vary since there are several different start displays to choose from during configuration.

Vent controller 5.0
 2017-07-08 14:29
 System: Normal run
 Sp: 22.0 Act: 22.5 °C

Sp and **Act** stand for Setpoint and Actual value.

Actual value = the current measured temperature

Setpoint = the desired configured temperature

You can navigate through the menu choices at this level by pressing the [▼] and [▲] buttons. Which menu items that are shown depends on the access level of the user and the configured inputs/outputs and functions.

Below, all possible menu entries are shown.

- ✓ Ventilation
- ✓ Additional function
- ✓ Time settings
- ✓ Alarm events
- ✓ Configuration
- ✓ Access rights

To enter a higher menu level, press the [▶] button when the display marker is located at the menu item you wish to enter. At each level there may be several new menus through which you may browse using the [▲] and [▼] buttons. When there are further submenus linked to a menu or menu item, it is indicated by an arrow symbol at the right-hand edge of the display. To choose one, press the [▶] button again. To return to a lower menu level, press the [◀] button.

Changing values

When you are at a position where it is possible to change one or more values, and your access level is high enough, you can edit the existing value, or enter a new one. After changing the value, you confirm the input with the [OK] button, or undo the change by pressing the [C]/ [▼▶] buttons for a short while until the original value reappears in the window and change mode is exited. These actions are described in detail in the following sections.

Editing an existing value

1. Press the [OK] button to go to change mode. A flashing cursor appears. If there are multiple editable values in one menu, press the [OK] button until the value you want to change flashes.
 2. Move the cursor to the right and to the left with the navigation buttons [▶] and [◀].
 3. The value at the cursor can now be changed in the following ways:
 - ✓ Erase the current digit or character with the [C]/ [▼▶] buttons.
 - ✓ Use the [▲] and [▼] buttons to increase or decrease the value at the cursor. Editable texts can also be changed with this method.
 - ✓ If the character at the cursor is a decimal point, you cannot browse with the [▲] and [▼] buttons. You can however erase the decimal point with the [C]/ [▼▶] buttons.
 - ✓ If the cursor is placed to the right of the value, i.e. the character at the cursor is a space, you can add a decimal point with the [▼] button, or the figure 0 with the [▲] button.
 - ✓ If you require a negative number, move the cursor to the leftmost position and press the [▼] button to get a minus sign. Then edit the following digits to the required value.
 - ✓ Scroll up [▲] and down [▼] to browse through texts when there are several texts to choose from instead of numerical values.
- Press [OK] to confirm the change when the required value has been entered. Then the value you see in the window will be updated in the installation. After the value has been confirmed, the cursor will move to the next editable value in the current menu.

Logging on and off

- The controller has different access levels. The choice of access level determines which menus are shown, as well as which parameters can be changed in the displayed menus.
- ✓ **Guest** level does not require logging on, and only permits changes in running mode and gives read-only access to a limited number of menus.
 - ✓ **Operator** level gives the same access as Guest level, and in addition, access to change setpoints.

- Log on

1. Browse to Access Rights in the main menu and press [▶]

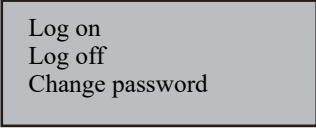

Log on
Log off
Change password

2. Select Log on and press [▶].

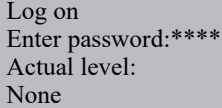

Log on
Enter password:****
Actual level:
None

3. Press [OK] to make a cursor marker appear at the first digit position.

4. Enter the password (4-digit code) by pressing [▲] until the correct digit is displayed. Press the [▶] to move to the next position. Repeat the procedure until all four digits are displayed, and press [OK] to confirm.

Note: The password for operator level is 3333. The password for the guest level is 5555.

- Log off

1. Go to Access Rights in the main menu and press [▶].

2. Select Log off and press [▶].

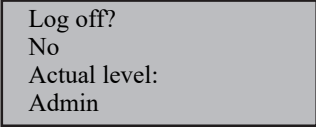

Log off?
No
Actual level:
Admin

3. Select Yes and press [OK].

Note: When logged in, the user will automatically be logged off to Guest after a settable time of inactivity (the default is 60 seconds).

Ventilation

Ventilation has up to six submenus:

Actual /Setpoint Temperature control Fan control PID controller Manual / Auto Status

- Actual/Setpoint

In this submenu, you can read all the actual values of the configured inputs of the circuit.

- Temperature control

In this submenu, you can read and set all the setpoints for the selected circuit. You need Operator or higher access level to be able to change setpoints.

Temperature Control Types

Application	Description																		
Supply air*	The supply air controller output is either a heating demand or a cooling demand depending on if the supply temperature is over or under the setpoint. Each sequence can be configured as heat, cool, exchanger, damper, compensation or not used and each sequence has its own PID-settings.																		
Supply air outdoor compensated*	<p>The supply air temperature setpoint is temperature compensated using a control curve. The temperature for compensation is configurable between all temperature sensors.</p> <p>The supply air temperature is kept at the setpoint value by controlling the output signals for sequences.</p> <table border="1"> <thead> <tr> <th>Outdoor temperature</th> <th>Setpoint supply temperature</th> </tr> </thead> <tbody> <tr> <td>-20</td> <td>25</td> </tr> <tr> <td>-15</td> <td>24</td> </tr> <tr> <td>-10</td> <td>23</td> </tr> <tr> <td>-5</td> <td>23</td> </tr> <tr> <td>0</td> <td>22</td> </tr> <tr> <td>5</td> <td>20</td> </tr> <tr> <td>10</td> <td>18</td> </tr> <tr> <td>15</td> <td>18</td> </tr> </tbody> </table>	Outdoor temperature	Setpoint supply temperature	-20	25	-15	24	-10	23	-5	23	0	22	5	20	10	18	15	18
Outdoor temperature	Setpoint supply temperature																		
-20	25																		
-15	24																		
-10	23																		
-5	23																		
0	22																		
5	20																		
10	18																		
15	18																		
Extract air cascade (default)	Cascade control of extract air temperature and supply air temperature to achieve a constant, settable room temperature. The extract air temperature is kept at the setpoint value by controlling the output signals for sequences.																		
Extract air dependent supply air*	A difference between extract air temperature and supply air temperature can be configured to maintain the supply air temperature setpoint to follow extract air temperature.																		

MENU STRUCTURE & FEATURES

Application	Description												
Extract air outdoor compensated	<p>A difference between extract air temperature and supply air temperature can be configured to maintain that the supply air temperature setpoint follows the extract air temperature.</p> <table border="1"> <caption>Data points for Extract temperature setpoint vs Outdoor temperature</caption> <thead> <tr> <th>Outdoor temperature</th> <th>Extract temperature setpoint</th> </tr> </thead> <tbody> <tr> <td>-20</td> <td>25</td> </tr> <tr> <td>-10</td> <td>23</td> </tr> <tr> <td>0</td> <td>22</td> </tr> <tr> <td>10</td> <td>18</td> </tr> <tr> <td>15</td> <td>18</td> </tr> </tbody> </table>	Outdoor temperature	Extract temperature setpoint	-20	25	-10	23	0	22	10	18	15	18
Outdoor temperature	Extract temperature setpoint												
-20	25												
-10	23												
0	22												
10	18												
15	18												

***Note:** Supply temperature sensor is not available on all unit types.

- Fan control

In this submenu, settings of the fan can be read and set. It is only visible for access level Operator and higher, and only editable for access level Service and higher.

Application	Description
Pressure	<p>Control of the fan speed using pressure transmitters.</p> <p>During pressure control, two separate analog output signals are used for supply and extract air and two separate analogue input signals for supply and extract air for pressure transmitters. The fan speeds are controlled, thereby maintaining constant pressure.</p>
Flow	<p>Instead of giving a pressure setpoint value, it is possible to use an airflow volume value in m³/h.</p> <p>The value from the pressure transmitter is recalculated to a volume flow and the fans will be controlled to give a constant flow.</p>
Manual (default)	<p>Use the manual setting if you want to manually set the speed of the fan</p> <p>Fans can be controlled at a fixed rotational speed. The rotational speed is selected by setting a fixed output signal (0 – 100%). There is one individual setpoint value for normal speed, for low speed and high speed. In this mode, pressure sensors are not needed.</p>

When running pressure/flow control or manual frequency control, it is possible to for the pressure/flow or output to be compensated. By using compensation, the fan can be run at low speed more of the time. The fan speed will increase only when necessary, thus saving energy.

This compensation can be made depending on any analog input such as supply air, extract air, room, outdoor temperature, humidity, CO₂ etc. It is possible to compensate either one or both fans at the same time. It is possible to set which fan that should be compensated, the supply or extract air fan.

The compensation can be selected to apply to both fans or one fan, to low, normal, high or all speeds or only when defrosting.

- PID control

In this submenu, the control parameters can be read and set. It is only visible for access level Operator and higher, and only editable for access level Service and higher.

Note: Changes must be made by technical personnel.

MENU STRUCTURE & FEATURES

- Manual/Auto

In this submenu, the ventilation unit can be set to manual mode. It is only visible for access level Operator and higher, and only editable for access level Service and higher.

Frequency controlled fans can be controlled at a fixed rotational speed. The rotational speed is selected by setting a fixed output signal (0 – 100%). There is one individual setpoint value for normal speed, for low speed and high speed.

Technical Specification

Variable	Read/write	Default value	Min/Max
Setpoint low speed supply air fan (%)	W	25	0/100
Setpoint low speed extract air fan (%)	W	25	0/100
Setpoint normal speed supply air fan (%)	W	50	0/100
Setpoint normal speed extract air fan (%)	W	50	0/100
Setpoint high speed supply air fan (%)	W	75	0/100
Setpoint high speed extract air fan (%)	W	75	0/100
Setpoint low speed supply air fan (Pa)	W	250	0/10000
Setpoint low speed extract air fan (Pa)	W	250	0/10000
Setpoint normal speed supply air fan (Pa)	W	500	0/10000
Setpoint normal speed extract air fan (Pa)	W	500	0/10000
Setpoint high speed supply air fan (Pa)	W	750	0/10000
Setpoint high speed extract air fan (Pa)	W	750	0/10000
Setpoint low speed supply air fan (m3/h)	W	1000	0/60000
Setpoint low speed extract air fan (m3/h)	W	1000	0/60000
Setpoint normal speed supply air fan (m3/h)	W	2000	0/60000
Setpoint normal speed extract air fan (m3/h)	W	2000	0/60000
Setpoint high speed supply air fan (m3/h)	W	3000	0/60000
Setpoint high speed extract air fan (m3/h)	W	3000	0/60000

- Status

In this submenu, the status of the ventilation unit can be read. Each function also has different sub-statuses.

Ventilation unit	<ul style="list-style-type: none"> ✓ Actual mode ✓ Schedule mode ✓ External stop ✓ Extended operation ✓ Extended operation time left (min) ✓ Manual mode HMI ✓ Manual mode HMI time left (s) ✓ Free cooling mode ✓ Night operation active last night ✓ Summer mode ✓ Fire alarm input ✓ Frost risk ✓ Internal alarm (alarm 194)
Sequence A to J	<ul style="list-style-type: none"> ✓ Analog output (%) ✓ Start ✓ Pump

Additional function

In this submenu, you can read the actual value and read/write the setpoint of a configured extra controller.

Feature	Menu path	Variable
Temperature control	Additional function ► Extra controller ► Temperature control	<ul style="list-style-type: none"> ✓ Digital start output start/stop point (%) ✓ Pump stop delay (min) ✓ Pump-kick hour (h) ✓ Pump running when outdoor temperature < (°C) ✓ Hysteresis to allow pump stop (°C)
PID settings	Additional function ► Extra controller ► PID controller	<ul style="list-style-type: none"> ✓ P-band (°C) ✓ I-time (s) ✓ D-time (s)
Manual / Auto	Additional function ► Extra controller ► Manual / Auto	<ul style="list-style-type: none"> ✓ Controller mode ✓ Manual set (%) ✓ Controller output (%) ✓ Start

Time Settings

Controller has a year-based clock function. This means that a week-schedule with holiday periods for a full year can be set. The clock has an automatic summertime/wintertime changeover.

It has individual schedules for each weekday plus a separate holiday setting. Up to 24 individual holiday periods can be configured. A holiday period can be anything from one day up to 365 days. Holiday schedules take precedence over other schedules.

Each day has up to four individual running periods. There are daily individual schedules for low speed, normal speed and high speed of the fan, each with up to four running periods.

The **Time settings** menu contains the submenus **Time schedule**, **Holiday schedule** and **Time/Date**

Time schedule,
Holiday schedule
Time/Date

- Time schedule

Fan low speed
Fan normal speed
Fan high speed
Extra time channel1
Extra time channel2
Extra time channel3
Extra time channel4

In the time schedules, four periods are available for each day of the week. Also, four periods are available for days that are configured as holidays in the holiday schedule. During the periods the assigned circuit is working with the corresponding setpoint. Outside of a period the system is off.

- Timer Low speed, Normal speed, High speed

There are sixteen separate settings menus for each timer channel, two for each weekday and two extra for holidays. Holiday schedules take precedence over other schedules.

For 24 hour running, set a period to 00:00 - 24:00.

To inactivate a period, set the time to 00:00 - 00:00. If both periods of a day are set to 00:00 - 00:00, the unit will not run at 1/1-speed that day.

Normal speed
Monday Per3-4 >
Per 1: 00:00 - 24:00
Per 2: 00:00 - 00:00

Normal speed
Monday
Per 3: 00:00 - 00:00
Per 4: 00:00 - 00:00

If you want to run the unit from one day to another, e.g. from Monday 22:00 to Tuesday 09:00, the desired running time for both must be entered.

Normal speed
Monday
Per 1: 22:00 - 24:00
Per 2: 00:00 - 00:00

Normal speed
Tuesday
Per 3: 00:00 - 09:00
Per 4: 00:00 - 00:00

Note: Should periods for the different speeds overlap, high speed takes precedence over normal speed, and normal speed takes precedence over low speed.

- Holiday Schedule

A holiday period can be any number of consecutive days from 1...365. The dates are in the format: MM:DD.

When the present date falls within a holiday period, the scheduler will use the settings for the weekday Holiday.

Name	Unit	Min	Max	Default	Description
Holiday Per.1 Start	MM:DD	01.01	31.12	00.00	The start date of holiday period 1
Holiday Per.1 End	MM:DD	01.01	31.12	00.00	The end date of holiday period 1
----	MM:DD				
Holiday Per.24 Start	MM:DD	01.01	31.12	00.00	The start date of holiday period 1
Holiday Per.24 End	MM:DD	01.01	31.12	00.00	The end date of holiday period 1

- Time/Date

This menu displays time, date and weekday, and it permits the setting of time and date.

Time is shown in 24 hour format.

Date is shown in the format YY:MM:DD.

Inputs/Outputs

In the sub menu Inputs/Outputs you can find and modify raw values and analog and digital inputs and outputs.

Raw values
Analog inputs
Digital inputs
Analog outputs
Digital outputs

Any control signal can be bound to any in- and output, the only restriction being that digital signals cannot be bound to analog inputs and vice versa. It is up to the user doing the binding to make sure that activated functions are bound to appropriate in- and outputs.

Note: The menu is adaptive and not all items will be shown, depending on previous selections.

Mode Switch

In addition to the items in the main menu, there is also an extra menu called Mode switch, that is reached by pressing **▶**] in the main menu. The mode switch changes the operation of the system.

Mode Switch Position	
0 - Off	Manual mode Off. System is switched off. No control function.
1 - Auto	Automatic mode. Control function depending on timer and settings.
2 - Low speed	Manual mode. System is forced to low speed of the fans.
3 - Normal speed	Manual mode. System is forced to normal speed of the fans.
4 - High speed	Manual mode. System is forced to high speed of the fans.

Alarm events and alarm handling

If an alarm condition occurs, an alarm is logged in an alarm list. The list shows the type of alarm, the alarm date and time and the alarm priority (A, B or C alarm).

Alarm priorities Alarms can be given different priority levels: A alarm, B alarm, C alarm or not active. There are three digital outputs that can be used as alarm outputs: Sum alarm, Sum alarm A and Sum Alarm B/C.

✓ A, B and C alarms all activate the sum alarm output, if it has been configured.

✓ Class A alarms also activate sum alarm A, and class B/C alarms activate sum alarm B/C.

✓ Class C alarms are removed from the alarm list when the alarm input resets even if the alarm has not been acknowledged.

- Inspect alarms

Press the [ALARM] / [**◀▲**] alarm buttons to view alarms.

✓ If there is more than one alarm at the same time, this is indicated by up/down arrow symbols on the right side of the screen. You can browse them using the navigation buttons [**▼**] and [**▲**].

✓ Press [**◀**] to exit alarm management and return to the previous menu.

- Acknowledge, block and unblock alarms

- ✓ Press the [OK] button to get a menu with the available alarm actions for the currently displayed alarm.
 - ✓ Select the required alarm action with the buttons [▼] and [▲].
 - ✓ Press the [OK] button to execute the action. At the left end of the bottom display line the alarm status is shown. For active, unacknowledged alarms the space is blank. Alarms that have been reset are indicated by the text Acknowledged. Active or blocked alarms are indicated by the text Acknowledged or Blocked.
- Acknowledged alarms will remain on the alarm list until the alarm input signal resets.
Blocked alarms remain on the alarm list until the alarm has been reset and the block has been removed. New alarms of the same type will not be activated as long as the block remains.

Caution! Blocking alarms can be potentially dangerous. A high log on access level is therefore required to block alarms.

- Alarm events

In the Alarm Events menu, there is an alarm log which contains the 40 latest alarm events. The latest event is shown at the top of the list. The alarm log is only used to view alarm history, which may simplify troubleshooting of the installation.

FUNCTIONS

Exchanger Control

The type of heat exchanger used can be plate or rotor, depending on the type of device.

- Rotary Exchanger Control

Rotary exchanger function only exists on units which have rotary exchanger. Rotational speed is controlled by the a sequence. A rotation guard can be connected to the digital input Rotary exchanger alarm (Alarm 67 Rotary changer alarm in the Alarm status). An alarm is generated if this input is not activated at the same time as the analogue output signal is higher than 1.0 V. It is also possible to use the heat exchanger to operate on and off depending on the outdoor temperature. The function controls an Outdoor controlled heat exchanger with a digital output that is activated when the outdoor temperature drops below a set value. There is also a rotor alarm for the open-close rotor heat exchanger.

The defrost sensor or the exhaust air temperature sensor can be used as the prevention sensor. The function cycle is activated when the sensor value used for the defrost function is lower than the preset minimum temperature value. While the cycle is active, Defrost mode is shown on the display.

- Bypass Control

By-pass function only exists on units which have by-pass module. The airflow through the exchanger is controlled by a by-pass damper. The damper is controlled by the analogue output sequence or by a type of digital outputs.

It is used when filtered fresh air is desired to be supplied to indoor without passing through heat exchanger (transition seasons). By checking the outside air temperature, return air temperature and set temperature values, it is decided whether the by-pass module will be opened or not.

-Bypass Control when defrosting

The airflow through the exchanger is controlled by a by-pass damper. The damper could be proportional or On/Off controlled. Defrosting is activated either when the digital signal Defrosting is activated in Application tool or when the value of the analogue input Defrosting temperature falls below the de-icing limit (-3°C), or when the Pressure extract air value rises above the set value for the current pressure. It is deactivated when the digital signal is reset, or alternatively when the analogue signal rises above the limit value plus a settable differential. If the digital input signal Defrosting guard exchanger is activated the exchanger is blocked, it will stay blocked as long as the digital input signal is active.

Fire Alarm Function

Feature	Variable
Select operation mode when fire/smoke alarm	<ul style="list-style-type: none"> ✓ Stopped ✓ Continuous run ✓ Running via normal start/ stop conditions ✓ Supply air fan run ✓ Extract air fan run
Supply air fan setpoint type when fire/smoke alarm	<ul style="list-style-type: none"> ✓ Auto ✓ Manual setpoint ✓ Manual output ✓ Low speed setpoint ✓ Normal speed setpoint ✓ High speed setpoint
Extract air fan setpoint type when fire/smoke alarm	<ul style="list-style-type: none"> ✓ Auto ✓ Manual setpoint ✓ Manual output ✓ Low speed setpoint ✓ Normal speed setpoint ✓ High speed setpoint

Freecooling (optional function)

This function is used during the summer to cool the building night-time using cool outdoor air, thereby reducing the need for cooling during the day and saving energy.

Free cooling requires an outdoor sensor and an extract air sensor.

Free heating (optional function)

If the outdoor temperature is higher than the indoor temperature and there is a heating demand, the recovery damper will not open for recovery but instead open fully for outdoor air. This may occur during low night-time outdoor temperatures, when the room has been cooled considerably and the outside heat is rising faster than indoors. This function is activated at the same time as Free cooling.

Freeze protection (optional functions)

A defrosting sensor or an exhaust air temperature sensor can be used as a prevention sensor. It is possible to set a starting temperature in. This represents both the minimum time that the function should be active, the supply air fan (SAF) and extract air fan (EAF) compensation, as well as the minimum time before the next prevention cycle should begin. While the cycle is active, Defrosting mode is shown in the display.

- Freeze protection control is available on all sequences.

- Exhaust air fan speed adjustable during defrosting:

- ✓ Auto
- ✓ Low
- ✓ Normal
- ✓ High

Water Heating Coil

If a sequence is configured as water heating, it's possible to select if the sequence should be controlled with freeze protection and which freeze protection sensor (1...3) that should be used. The sequence is controlled by the corresponding sequence analogue output for proportional control or digital output for on/off control.

The heater return water temperature is measured using the analog input Freeze protection temperature or the digital input Freeze protection guard, depending on the selection of freeze protection. Low temperatures will generate an internal, proportional signal that is used to force the heating valve open, thereby preventing freeze-up of the heater.

When the internal signal reaches 100 % or the digital input Freeze protection guard is activated, the unit is shut down, the heating output is set to completely open mode and an alarm is activated.

Note: The unit is restarted when the alarm has been acknowledged and the temperature for the frost protection sensor has risen above Alarm limitation running mode + P-band running mode.

Note: The accessory must be added for the function.

Water Cooling Coil

If a sequence is configured as water heating, it's possible to select if the sequence should be controlled with freeze protection and which freeze protection sensor (1...3) that should be used. The sequence is controlled by the corresponding sequence analogue output for proportional control or digital output for on/off control.

Note: The accessory must be added for the function.

Electrical Preheater

Electric heating is controlled using the analogue output sequence. On activation of the digital input Overheated electric heater the unit will be shut down, either according to the stop sequence or as an emergency shutdown. The unit will restart after the alarm has been acknowledged and Overheated electric heater has reset.

The digital output Pretreatment is set to preheating when the unit is started and the outdoor temperature is below the set heating start limit (default 8°C). If the outdoor temperature exceeds the set heating start limit by more than 1°C, preheating will be stopped.

Variable	Read/Write	Default value	Min/Max
Pretreatment output	R		
Activate preheater when outdoor temperature < (°C)	W	8	-40/150
Activate precooler when outdoor temperature > (°C)	W	19	-40/150
Hysteresis (°C)	W	1	0/10
Min difference between outdoor and intake air temperature	W	1	0/20
Pretreatment block time if difference below min (h)	W	6	0/24
Min run time (min)	W	5	0/600

Note: 63- Electric heating is overheated alarm means that the fans will be immediately stopped when there is an overheating alarm, regardless of the set cool-down time. Pretreatment always starts at start-up of the unit, if the outdoor temperature so permits.

Note: The accessory must be added for the function.

Electrical Postheater

Electric heating is controlled using the analogue output sequence. On activation of the digital input Overheated electric heater the unit will be shut down, either according to the stop sequence or as an emergency shutdown. The unit will restart after the alarm has been acknowledged and Overheated electric heater has reset.

Note: 63- Electric heating is overheated alarm means that the fans will be immediately stopped when there is an overheating alarm, regardless of the set cool-down time. Pretreatment always starts at start-up of the unit, if the outdoor temperature so permits.

Note: The accessory must be added for the function.

Damper Control

The outdoor air and exhaust air ducts close-off dampers can be controlled by digital outputs. When using pressure controlled fans the digital activation signal is activated as soon as the fan has start conditions. This signal can be used to open the close-off damper.

Note: When the unit is stopped it's possible to configure a delay time before the Outdoor air damper and Exhaust air damper is closing.

✓ Outdoor air damper close delay: 0-300 seconds (Default: 0 s)

✓ Exhaust air damper close delay: 0-300 seconds (Default: 0 s)

Constant Flow Control

When running pressure/flow control, it is possible to for the pressure/flow or output to be compensated. By using compensation, the fan can be run at low speed more of the time. The fan speed will increase only when necessary, thus saving energy.

This compensation can be made depending on any analog input such as supply air, extract air, room, outdoor temperature, humidity, CO₂ etc.

It is possible to compensate either one or both fans at the same time. It is possible to set which fan that should be compensated, the supply or extract air fan.

Note: The accessory must be added for the function.

Constant Pressure Control

When running pressure/flow control, it is possible to for the pressure/flow or output to be compensated. By using compensation, the fan can be run at low speed more of the time. The fan speed will increase only when necessary, thus saving energy.

This compensation can be made depending on any analog input such as supply air, extract air, room, outdoor temperature, humidity, CO₂ etc.

It is possible to compensate either one or both fans at the same time. It is possible to set which fan that should be compensated, the supply or extract air fan.

Note: The accessory must be added for the function.

CO2 Control

Fan speeds are automatically changed based on CO2 sensors. The fan speed will increase only when necessary, thus saving energy. It is possible to compensate either one or both fans at the same time. It is possible to set which fan that should be compensated, the supply or extract air fan.

Variable	Read/Write	Default value	Min/Max
CO2 room/extract air (ppm)	R		
Setpoint mixing damper (ppm)	W	1000	0/2000

Note: The accessory must be added for the function.

Humidity

Fan speeds are automatically changed based on humidity sensors. The fan speed will increase only when necessary, thus saving energy.

It is possible to compensate either one or both fans at the same time. It is possible to set which fan that should be compensated, the supply or extract air fan.

Variable	Read/Write	Default value	Min/Max
Humidity outdoor (%rH)	R		
Humidity room/extract air (%rH)	R		
Humidity supply air (%rH)	R		
Setpoint humidity room/extract air (%rH)	W	50	0/100
Humidity control signal (%)	R		

Note: The accessory must be added for the function.

Change language

The display language can be changed either by the front display, in the web interface.

- Front display menu:

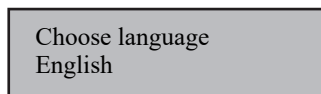

Note: This menu is also accessible by holding the [OK] button pressed during power-up or by pressing the [▶] button four times when the start display is shown.

- Web interface:

Account settings ▶ Language

Port 1 and Port 2

The controller can have one or two serial ports. In a controller with two serial ports, both ports have the same functions. However, they can not both be configured to have the same function at the same time, except that both can be slaves.

Function	Connection to	Format	Baud
EXDline slave	Application tool or SCADA system	801	9600
EXDline master	Pressure transmitters, Expansion units or Room units	801	9600
Modbus slave	SCADA system via Modbus or master controller	8N1	9600
Modbus master	Fans, Rotary exchanger, Pressure transmitters, Damper actuators and Wireless receivers	8N1	9600
BACnet MS/TP slave	BACnet SCADA or BACnet master controller	801	9600

BACnet

The controller is capable of communication via the BACnet -protocol, using either IP or MS/TP data link formats.

In order to connect a controller to a BAS (Building Automation System) via BACnet/IP, a controller with a TCP/IP port is required. To connect to a BAS via BACnet MS/TP, a controller with an RS485 communication port is required.

Note: All menus in Application tool are adaptive, which means that they adapt to the function/application you choose to set up. Therefore, not all menu items are available for all applications.

IP Configuration

IP configuration can be made in display.

The Dynamic Host Configuration Protocol (DHCP) is a network protocol used on Internet Protocol (IP) networks for dynamic distribution of network configuration parameters, such as IP addresses, DNS servers and other services.

The controller can be configured to either obtain an IP address from a DHCP server (dynamic) or the address can be set manually (static). If you wish to set a static IP address for the controller, enter the IP address you wish to use along with the subnet mask, gateway address and DNS server address.

In the display you do as follows below:

TCP/IP

DHCP: Yes
Set static IP
Running IP
-

IP
192.168.001.234
Subnet mask
255.255.255.000

Running subnet mask

-

Running gateway

-

Running DNS1

192.168.001.001

Running DNS2

192.168.001.001

BACnet List

The parameters are not available in all units, find the parameter suitable for your unit from the list.

#	keyname	Object-name	Object-type	Object-instance	Description	Settable	Default	Unit-code
@DeviceName.	AlaAcknowAll	AlaAcknowAll	5	10000	Command to acknowledge all alarms	Y		
@DeviceName.	FilterAlarmReset	FilterAlarmReset	5	10001	Resets the filter alarm counter	Y		
@DeviceName.	SumAlarm	SumAlarm	5	20007	Sumalarm	N		
@DeviceName.	SumAlarmA	SumAlarmA	5	20008	A-alarm	N		
@DeviceName.	SumAlarmB	SumAlarmB	5	20009	B-alarm	N		
@DeviceName.	SumAlarmC	SumAlarmC	5	20010	C-alarm	N		
@DeviceName.	Firealarm	Firealarm	5	20068	Fire alarm	N		
@DeviceName.	RotorAlarm	RotationalGuardExchanger	5	20088	Rotor Alarm	N		
@DeviceName.	Internalbatteryerror	Internalbatteryerror	5	20088	Internal battery error	N		
@DeviceName.	Timeforservice	Timeforservice	5	20089	Time for service	N		
@DeviceName.	Highsupplyairtemp	Highsupplyairtemp	5	20096	High supply air temp	N		
@DeviceName.	Lowsupplyairtemp	Lowsupplyairtemp	5	20097	Low supply air temp	N		
@DeviceName.	CommErrorDevice	CommErrorDevice	5	20202	PDT communication Alarm	N		
@DeviceName.	InternalError	InternalError	5	20204	Internal error	N		
@DeviceName.	DO_1	Rotor Start	Binary	20333	DO_1 (Rotay Heat Exchanger Start) 0-Close 1-Open	N		
@DeviceName.	DO_3	Outdoor Air Damper Start	Binary	20335	DO_3 (Outdoor Air Damper Start) 0-Close 1-Open	N		
@DeviceName.	DO_4	Running Indication	Binary	20336	DO_3 (Running Indication) 0-Closed 1-Running	N		
@DeviceName.	Minute	Minute	2	30503	Minute	Y		95
@DeviceName.	Hour	Hour	2	30504	Hour	Y		95
@DeviceName.	WDay	WDay	2	30505	Day of Week (1-7, 1=Monday)	Y		95
@DeviceName.	Week	Week	2	30506	Week number	Y		95
@DeviceName.	Date	Date	2	30507	Day of month	Y		95
@DeviceName.	Month	Month	2	30508	Month	Y		95

# keyname	Object-name	Object-type	Object-instance	Description	Settable	Default	Unit-code
@DeviceName.Year	Year	2	30509	Year	Y		95
VentSettings.S_DOSelect_OutdoorAirDamper	OutdoorAirDamper		30783	Running mode fresh air damper: 0 = Close, 1 = Open, 2 = Auto	Y	2	
@DeviceName.AirUnitAutoMode	AirUnitAutoMode	19	30788	Running mode air unit: 0 = Off, 1 = Manual, 2 = Auto, 3 = Low speed 4 = Normal speed, 5 = High speed	Y	3	
@DeviceName.AirUnitManual	AirUnitManual	19	30789	Manual setting for Air unit in manual mode 0 = Stop, 1 = Starting up, 2 = Low speed run, 3 = Normal speed run, 4 = High speed run, 5 = Heating support run, 6 = Cooling support run, 7 = CO2 Run, 8 = Free cool run, 9 = Fan stop run 10 = Fire run, 11 = Smoke run, 12 = Recirculation run, 13 = Delcing run	Y	0	
@DeviceName.SAFAutoMode	SAFAutoMode	19	30790	Running mode SAF: 0 = Off, 1 = Manual output, 2 = Auto, 3 = Manual setpoint, 4 = Low speed, 5 = Normal speed, 6 = High speed	Y	2	
@DeviceName.SAFManualSetpoint	SAFManualSetpoint	2	30791	Man. setp. SAF if Man. mode	Y	0	95
@DeviceName.SAFManualOutput	SAFManualOutput	2	30792	Man. output SAF if Man. mode	Y	0	98
@DeviceName.EAFAutoMode	EAFAutoMode	19	30793	Running mode EAF: 0 = Off, 1 = Manual output, 2 = Auto, 3 = Manual setpoint, 4 = Low speed, 5 = Normal speed, 6 = High speed	Y	2	
@DeviceName.EAFManualSetpoint	EAFManualSetpoint	2	30794	Man. setp. EAF if Man. mode	Y		95
@DeviceName.EAFManualOutput	EAFManualOutput	2	30795	Man. output EAF if Man. mode	Y		98
@DeviceName.SupplySetpoint	SupplySetpoint	2	30811	Setp. supply air temp. when constant supply air temp. func.	Y		(configurable)
@DeviceName.ExtractSetpoint	ExtractSetpoint	2	30812	Setp. extract air temp. if extract air temp cont. func.	Y		(configurable)
@DeviceName.SupplySetpointMax	SupplySetpointMax	2	30813	Max limit of supply setp. when cascade cont.	Y		(configurable)
@DeviceName.SupplySetpointMin	SupplySetpointMin	2	30814	Min limit of supply setp. when cascade cont.	Y		(configurable)
@DeviceName.SupplySetpOffsetLow	SupplySetpOffsetLow	2	30815	Temp. setp. Offset in low speed	Y		(configurable)
@DeviceName.SupplySetpOffsetHigh	SupplySetpOffsetHigh	2	30816	Temp. setp. Offset in high speed	Y		(configurable)
@DeviceName.SAFLowspeedAirFlow	SAFLowspeedAirFlow	2	30841	Setp. full sp. supply air fan flow.	Y		(configurable)
@DeviceName.SAFNormalspeedAirFlow	SAFNormalspeedAirFlow	2	30842	Setp. reduced sp. supply air fan flow.	Y		(configurable)

# keyname	Object-name	Object-type	Object-instance	Description	Settable	Default	Unit-code
@DeviceName. SAFHHighspeedAirFlow	SAFHHighspeedAirFlow	2	30843	Setp. reduced sp. supply air fan flow.	Y		(configurable)
@DeviceName. EAFLowSpeedAirFlow	EAFLowSpeedAirFlow	2	30844	Setp. reduced sp. supply air fan flow.	Y		(configurable)
@DeviceName. EAFNormalspeedAirFlow	EAFNormalspeedAirFlow	2	30845	Setp. full sp. Extract air fan flow.	Y		(configurable)
@DeviceName. EAFHighspeedAirFlow	EAFHighspeedAirFlow	2	30846	Setp. high sp. Extract air fan flow.	Y		(configurable)
@DeviceName. .SAFLowSpeedOutput	SAFLowSpeedOutput	2	30847	Output signal low speed SAF if Freq. cont. manually	Y		98
@DeviceName. SAFNormalSpeedOutput	SAFNormalSpeedOutput	2	30848	Output signal normal speed SAF if Freq. cont. manually	Y		98
@DeviceName. SAFHHighspeedOutput	SAFHHighspeedOutput	2	30849	Output signal high speed SAF if Freq. cont. manually	Y		98
@DeviceName. EAFLowSpeedOutput	EAFLowSpeedOutput	2	30850	Output signal low speed EAF if Freq. cont. manually	Y		98
@DeviceName. EAFNormalSpeedOutput	EAFNormalSpeedOutput	2	30851	Output signal normal speed EAF if Freq. cont. manually	Y		98
@DeviceName. EAFHighspeedOutput	EAFHighspeedOutput	2	30852	Output signal high speed EAF if Freq. cont. manually	Y		98
@DeviceName. SAFLowSpeedPressOffset	EAFHighspeedOutput	2	30853	Offset SAF press. low speed	Y		(configurable)
@DeviceName. SAFHighSpeedPressOffset	SAFHighSpeedPressOffset	2	30854	Offset SAF press. high speed	Y		(configurable)
@DeviceName. SAFLowSpeedAirFlowOffset	SAFLowSpeedAirFlowOffset	2	30855	Offset SAF air flow low speed	Y		(configurable)
@DeviceName. SAFHighSpeedAirFlowOffset	SAFHighSpeedAirFlowOffset	2	30856	Offset SAF air flow high speed	Y		(configurable)
@DeviceName. SAFLowSpeedOutputOffset	SAFLowSpeedOutputOffset	2	30857	Offset SAF output low speed	Y		98
@DeviceName. SAFHighSpeedOutputOffset	SAFHighSpeedOutputOffset	2	30858	Offset SAF output high speed	Y		98
@DeviceName. EAFLowSpeedPressOffset	EAFLowSpeedPressOffset	2	30859	Offset EAF press. low speed	Y		(configurable)
@DeviceName. EAFHighSpeedPressOffset	EAFHighSpeedPressOffset	2	30860	Offset EAF press. high speed	Y		(configurable)
@DeviceName. EAFLowSpeedAirFlowOffset	EAFHighSpeedPressOffset	2	30861	Offset EAF air flow low speed	Y		(configurable)

# keyname	Object-name	Object-type	Object-instance	Description	Settable	Default	Unit-code
@DeviceName. EAFHighSpeedAirFlowOffset	EAFHighSpeedAirFlowOffset	2	30862	Offset EAF air flow high speed	Y		(configurable)
@DeviceName. EAFLowSpeedOutputOffset	EAFLowSpeedOutputOffset	2	30863	Offset EAF output low speed	Y		98
@DeviceName. EAFHighSpeedOutputOffset	EAFHighSpeedOutputOffset	2	30864	Offset EAF output high speed	Y		98
@DeviceName.AlarmOutput	AlarmOutput	2	31000	Alarm output of configured alarm number	Y		95
@DeviceName. SupplyHighAlarmLimit	SupplyHighAlarmLimit	2	31002	High alarm limit supply air temp	Y		(configurable)
@DeviceName. SupplyLowAlarmLimit	SupplyLowAlarmLimit	2	31003	Low alarm limit supply air temp	Y		(configurable)
@DeviceName. ExtractAirTempHigh	ExtractAirTempHigh	2	31007	High alarm limit Extract air temp	Y		(configurable)
@DeviceName. ExtractAirTempLow	ExtractAirTempLow	2	31008	Low alarm limit Extract air temp	Y		(configurable)
@DeviceName. AI_OutDoorTemp	AI_OutDoorTemp	2	40290	Outdoor temp	N		(configurable)
@DeviceName. AI_SupplyAirTemp	AI_SupplyAirTemp	2	40292	Supply air temp.	N		(configurable)
@DeviceName. AI_ExhaustAirTemp	AI_ExhaustAirTemp	2	40293	Exhaust air temp	N		(configurable)
@DeviceName. AI_ExtractAirTemp	AI_ExtractAirTemp	2	40294	Extract air temp	N		(configurable)
@DeviceName. AI_SAFFlow	AI_SAFFlow	2	40313	Supply air fan flow	N		(configurable)
@DeviceName. AI_EAFFlow	AI_EAFFlow	2	40314	Extract air fan flow	N		(configurable)
@DeviceName. AI_FilterGuard1	AI_FilterGuard1	2	40335	Ana. filter 1 value	N		(configurable)
@DeviceName. SAFAirFlow	SAFAirFlow	2	40359	Counted air flow m3/h supply air	N		(configurable)
@DeviceName. EAFAirFlow	EAFAirFlow	2	40360	Counted air flow m3/h extract air	N		(configurable)
@DeviceName.AO_SeqY3	Cooling Battery	2	40365	Cooling Battery position	N		
@DeviceName.AO_SAF	AO_SAF	2	40375	Supply air fan cont.	N		98
@DeviceName.AO_EAF	AO_EAF	2	40376	Extract air fan cont.	N		98

# keyname	Object-name	Object-type	Object-instance	Description	Settable	Default	Unit-code
@DeviceName. UnitMode	UnitMode	19	40428	Run mode. 0=Stop, 1=Starting up, 2=Low speed run, 3=Normal speed run 4=High speed run, 5=Heating support run 6=Cooling support run, 7=CO2 Run 8=Free cool run, 9=Fan stop run 10=Fire run, 11=Smoke run 12=Recirculation run, 13=Delcing run	N		
@DeviceName.UnitModeControl	UnitModeControl	19	40429	Indicates what is triggering the curr. run mode Indicates what is triggering the current run mode 1= Time schedule, 2= Manual run 3= Digital Input, 4= Alarm 5= External control, 6= Service stop	N		
@DeviceName.ActiveSeqType	ActiveSeqType	19	40430	Active seq. type	N		
@DeviceName.SAFRunTime	SAFRunTime	2	40434	Run. Time supply air fan	N		71
@DeviceName.EAFRunTime	EAFRunTime	2	40435	Run. Time extract air fan	N		71
@DeviceName.SAF	SAF	2	40449	Cont. signal supply air fan	N		98
@DeviceName.EAF	EAF	2	40450	Cont. signal extract air fan	N		98
@DeviceName. SAFSpeed	SAFSpeed	19	40451	SAF speed in auto and manual mode 0= Off, 1= Low speed, 2= normal speed 3= high speed, 4= Special	N		
@DeviceName. EAFSpeed	EAFSpeed	19	40452	EAF speed, 0= Off, 1= Low speed, 2= normal speed, 3= high speed 4= Special	N		

Alarm List

Details about the alarm on the display can be found in the table.

No	Alarm text	Prio	Delay	Limit	Default action	Description
1	Malfunction supply air fan 1	B	120 s			Malfunction supply air fan 1
2	Malfunction supply air fan 2	B	120 s			Malfunction supply air fan 2
3	Malfunction supply air fan 3	B	120 s			Malfunction supply air fan 3
4	Malfunction supply air fan 4	B	120 s			Malfunction supply air fan 4
5	Malfunction supply air fan 5	B	120 s			Malfunction supply air fan 5
6	Malfunction extract air fan 1	B	120 s			Malfunction extract air fan 1
7	Malfunction extract air fan 2	B	120 s			Malfunction extract air fan 2
8	Malfunction extract air fan 3	B	120 s			Malfunction extract air fan 3
9	Malfunction extract air fan 4	B	120 s			Malfunction extract air fan 4
10	Malfunction extract air fan 5	B	120 s			Malfunction extract air fan 5
11	Alarm supply air fan 1	A	0 s			Alarm from frequency converter SAF via Modbus communication
12	Alarm supply air fan 2	A	0 s			Alarm from frequency converter SAF 2 via Modbus communication

No	Alarm text	Prio	Delay	Limit	Default action	Description
13	Alarm supply air fan 3	A	0 s			Alarm from frequency converter SAF 3 via Modbus communication
14	Alarm supply air fan 4	A	0 s			Alarm from frequency converter SAF 4 via Modbus communication
15	Alarm supply air fan 5	A	0 s			Alarm from frequency converter SAF 5 via Modbus communication
16	Alarm extract air fan 1	A	0 s			Alarm from frequency converter EAF via Modbus communication
17	Alarm extract air fan 2	A	0 s			Alarm from frequency converter EAF 2 via Modbus communication
18	Alarm extract air fan 3	A	0 s			Alarm from frequency converter EAF 3 via Modbus communication
19	Alarm extract air fan 4	A	0 s			Alarm from frequency converter EAF 4 via Modbus communication
20	Alarm extract air fan 5	A	0 s			Alarm from frequency converter EAF 5 via Modbus communication
21	Warning supply air fan 1	C	0 s			Warning from frequency converter SAF 1 via Modbus communication
22	Warning supply air fan 2	C	0 s			Warning from frequency converter SAF 2 via Modbus communication
23	Warning supply air fan 3	C	0 s			Warning from frequency converter SAF 3 via Modbus communication
24	Warning supply air fan 4	C	0 s			Warning from frequency converter SAF 4 via Modbus communication
25	Warning supply air fan 5	C	0 s			Warning from frequency converter SAF 5 via Modbus communication
26	Warning extract air fan 1	C	0 s			Warning from frequency converter EAF 1 via Modbus communication
27	Warning extract air fan 2	C	0 s			Warning from frequency converter EAF 2 via Modbus communication
28	Warning extract air fan 3	C	0 s			Warning from frequency converter EAF 3 via Modbus communication
29	Warning extract air fan 4	C	0 s			Warning from frequency converter EAF 4 via Modbus communication
30	Warning extract air fan 5	C	0 s			Warning from frequency converter EAF 5 via Modbus communication
31	External operation supply air fan	C	120 s			SAF run-signal received when unit is stopped
32	External operation extract air fan	C	120 s			EAF run-signal received when unit is stopped
35	Malfuction pump heater	B	5 s			Malfuction pump, heating circuit
36	Malfuction pump cooler	B	5 s			Malfuction pump, cooling circuit
39	Malfuction damper	B	90 s			Malfuction damper (via Modbus)
43	Malfuction sequence A	-	5 s			Malfuction sequence A
44	Malfuction sequence B	-	5 s			Malfuction sequence B
45	Malfuction sequence C	-	5 s			Malfuction sequence C
46	Malfuction sequence D	-	5 s			Malfuction sequence D
47	Malfuction sequence E	-	5 s			Malfuction sequence E
48	Malfuction sequence F	-	5 s			Malfuction sequence F
49	Malfuction sequence G	-	5 s			Malfuction sequence G
50	Malfuction sequence H	-	5 s			Malfuction sequence H
51	Malfuction sequence I	-	5 s			Malfuction sequence I
52	Malfuction sequence J	-	5 s			Malfuction sequence J
53	Filter alarm supply air	B	180 s	CURVE		Filter alarm supply air pressure switch or analogue filter switch activated. The analogue filter switch may be flow dependent.
54	Filter alarm extract air	B	180 s	CURVE		Filter alarm extract air pressure switch or analogue filter switch activated. The analogue filter switch may be flow dependent.

No	Alarm text	Prio	Delay	Limit	Default action	Description
55	Alarm low air flow	B	5 s		Normal stop	Flow switch activated
56	Freeze protection guard	A	0 s		Fast stop	External frost protection thermostat activated
57	Defrosting guard exchanger	-	0			Exchanger deicing pressure switch activated
58	Fire alarm	A	0 s		Fast stop	Fire alarm activated
60	External stop	C	0 s		Normal stop	"External stop" activated
61	External alarm	B	0 s			External alarm activated
62	Service stop	B	0 s			Service stop activated
63	Electric heating is overheated	A	0 s		Normal stop	Heater high temperature limit switch activated
64	Warning freeze protection	B	30 min	50 %		Frost protection function is overriding the control of the heater output
66	Defrosting alarm	-	2 s			Exchanger deicing activated by deicing sensor
67	Rotary exchanger alarm	B	20 s			Exchanger rotation guard alarm
68	Extra alarm 1	-	0 s			Extra alarm 1 on digital input
69	Extra alarm 2	-	0 s			Extra alarm 2 on digital input
70	Extra alarm 3	-	0 s			Extra alarm 3 on digital input
71	Extra alarm 4	-	0 s			Extra alarm 4 on digital input
72	Extra alarm 5	-	0 s			Extra alarm 5 on digital input
73	Extra alarm 6	-	0 s			Extra alarm 6 on digital input
74	Extra alarm 7	-	0 s			Extra alarm 7 on digital input
75	Extra alarm 8	-	0 s			Extra alarm 8 on digital input
76	Extra alarm 9	-	0 s			Extra alarm 9 on digital input
77	Extra alarm 10	-	5 s			Extra alarm 10 on digital input
78	Internal battery error	A	0 s			Internal battery needs replacing
79	Alarm service interval	C	0 s			Time for service
80	Restart blocked after power on	B	0 s		Fast stop	Restart blocked due to earlier power failure
81	Deviation alarm supply air temp.	B	30 min	10 °C		Supply air temp deviates too much from the setpoint
82	Deviation alarm supply air fan	-	30 min	50 Pa		Supply air pressure deviates too much from the setpoint
83	Deviation alarm extract air fan	-	30 min	50 Pa		Extract air pressure deviates too much from the setpoint
84	Deviation alarm humidity control	-	30 min	10 %		The room humidity deviates too much from the setpoint
86	High supply air temperature	B	5 s	30 °C		Supply air temp too high
87	Low supply air temperature	B	5 s	10 °C		Supply air temp too low
88	Supply air temperature max limit	-	0 s			Maximum limiting of supply air temp active
89	Supply air temperature min limit	-	0 s			Minimum limiting of supply air temp active
92	High extract air temperature	B	30min	30 °C		High extract air temp during extract air control
93	Low extract air temperature	B	30min	10 °C		Low extract air temp during extract air control
94	High outdoor air temperature	-	0 s	40 °C		Outdoor temperature is too high
95	Low outdoor air temperature	-	0 s	-30 °C		Outdoor temperature is too low
96	Freeze protection alarm 1	A	0 s		Fast stop	Frost protection temperature 1 below frost limit value

No	Alarm text	Prio	Delay	Limit	Default action	Description
97	Freeze protection alarm 2	A	0 s		Fast stop	Frost protection temperature 2 below frost limit value
98	Freeze protection alarm 3	A	0 s		Fast stop	Frost protection temperature 3 below frost limit value
113	Manual operation air handling unit	C	0 s			The unit is in manual mode
114	Manual operation supply air	C	0 s			Supply air temp controller in manual control
115	Manual operation supply air fan	C	0 s			Supply air fan in manual control
116	Manual operation extract air fan	C	0 s			Extract air fan in manual control
117	Manual operation heater	C	0 s			The heater is in manual mode
118	Manual operation exchanger	C	0 s			Heat exchanger output in manual control
119	Manual operation cooler	C	0 s			Cooling output in manual control
120	Manual operation damper	C	0 s			Damper output in manual control
121	Manual operation pump heater	C	0 s			Heating circulation pump in manual control
125	Manual operation damper outdoor air	C	0 s			Fresh air damper in manual control
128	Manual control sequence A	-	0 s			Manual control of sequence A
129	Manual control sequence B	-	0 s			Manual control of sequence B
130	Manual control sequence C	-	0 s			Manual control of sequence C
131	Manual control sequence D	-	0 s			Manual control of sequence D
132	Manual control sequence E	-	0 s			Manual control of sequence E
133	Manual control sequence F	-	0 s			Manual control of sequence F
134	Manual control sequence G	-	0 s			Manual control of sequence G
136	Manual control sequence H	-	0 s			Manual control of sequence H
137	Manual control sequence I	-	0 s			Manual control of sequence I
138	Manual control sequence J	-	0 s			Manual control of sequence J
139	Input in manual operation	C	0 s			Analogue or digital input in manual mode
143	Manual operation pretreatment	C	0 s			Pretreatment in manual mode
144	Sensor error outdoor air temperature	B	5 s			Malfunction in connected sensor
146	Sensor error supply air temperature	B	5 s			Malfunction in connected sensor
147	Sensor error exhaust air temperature	B	5 s			Malfunction in connected sensor
148	Sensor error extract air temperature	B	5 s			Malfunction in connected sensor
165	Sensor error pressure supply air	B	5 s			Malfunction in connected sensor
166	Sensor error pressure extract air	B	5 s			Malfunction in connected sensor
167	Sensor error flow supply air	B	5 s			Malfunction in connected sensor
168	Sensor error flow extract air	B	5 s			Malfunction in connected sensor
169	Sensor error flow exch. supply air	B	5 s			Malfunction in connected sensor
170	Sensor error press. exch. extr. air	B	5 s			Malfunction in connected sensor
171	Sensor error defrosting temperature	B	5 s			Malfunction in connected sensor
172	Sensor error freeze protect. temp. 1	B	5 s			Malfunction in connected sensor
173	Sensor error freeze protect. temp. 2	B	5 s			Malfunction in connected sensor

No	Alarm text	Prio	Delay	Limit	Default action	Description
174	Sensor error freeze protect. temp. 3	B	5 s			Malfunction in connected sensor
175	Sensor error CO2 room/extract air	B	5 s			Malfunction in connected sensor
176	Sensor error humidity room/ extr. air	B	5 s			Malfunction in connected sensor
177	Sensor error humidity supply air	B	5 s			Malfunction in connected sensor
178	Sensor error humidity outdoor	B	5 s			Malfunction in connected sensor
180	Signal error external control SAF	B	5 s			Malfunction in connected sensor
181	Signal error external control EAF	B	5 s			Malfunction in connected sensor
187	Sensor error external temp. setpoint	B	5 s			Malfunction in connected sensor
188	Signal error external flow setpoint	B	5 s			Malfunction in connected sensor
189	Sensor error press. filter supp. air	B	5 s			Malfunction in connected sensor
190	Sensor error press. filter extr. air	B	5 s			Malfunction in connected sensor
192	Communication fault device	C	0 s			Communication error to a device
194	Internal error	-	60 s			Internal Error

Panel Installation

- Cabling

The connection cable is available in two versions, 3 m or 10 m. If a connection cable is instead manufactured by the user, its maximum usable length is 100 m.

- Mounting



Figure 1. The cable is led through the outlet

Panel can be mounted on a wall or a device box (cc 60 mm). It can also be mounted on a cabinet front using the supplied magnetic tape. The magnetic strips are pasted onto the back of the unit. When using this mounting, the cable should be led through the alternate outlet at the bottom of the wiring compartment. See Figure 1.

It is also advisable to place a cable tie in accordance with Figure 2 in order to prevent a cable being torn from the display. E3-DSP can also be used as a hand-held terminal.

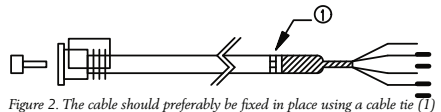
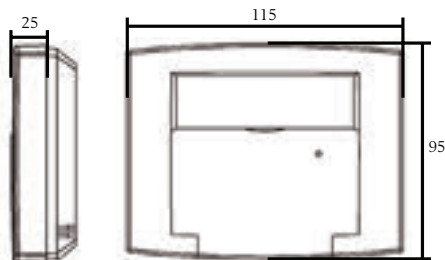

Figure 2. The cable should preferably be fixed in place using a cable tie (1)

- Dimensions



Panel Installation

- Cabling

The connection cable is available in two versions, 3 m or 10 m. If a connection cable is instead manufactured by the user, its maximum usable length is 100 m.

- Mounting



Figure 1. The cable is led through the outlet

Panel can be mounted on a wall or a device box (cc 60 mm). It can also be mounted on a cabinet front using the supplied magnetic tape. The magnetic strips are pasted onto the back of the unit. When using this mounting, the cable should be led through the alternate outlet at the bottom of the wiring compartment. See Figure 1.

It is also advisable to place a cable tie in accordance with Figure 2 in order to prevent a cable being torn from the display. E3-DSP can also be used as a hand-held terminal.

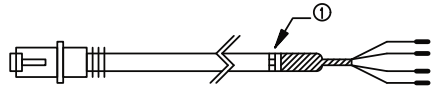
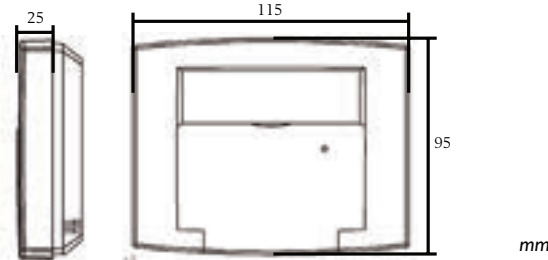
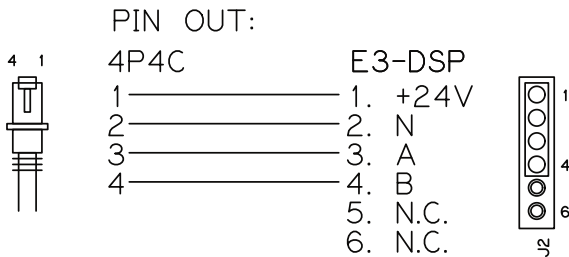

Figure 2. The cable should preferably be fixed in place using a cable tie (1)

- Dimensions



- Cable connections



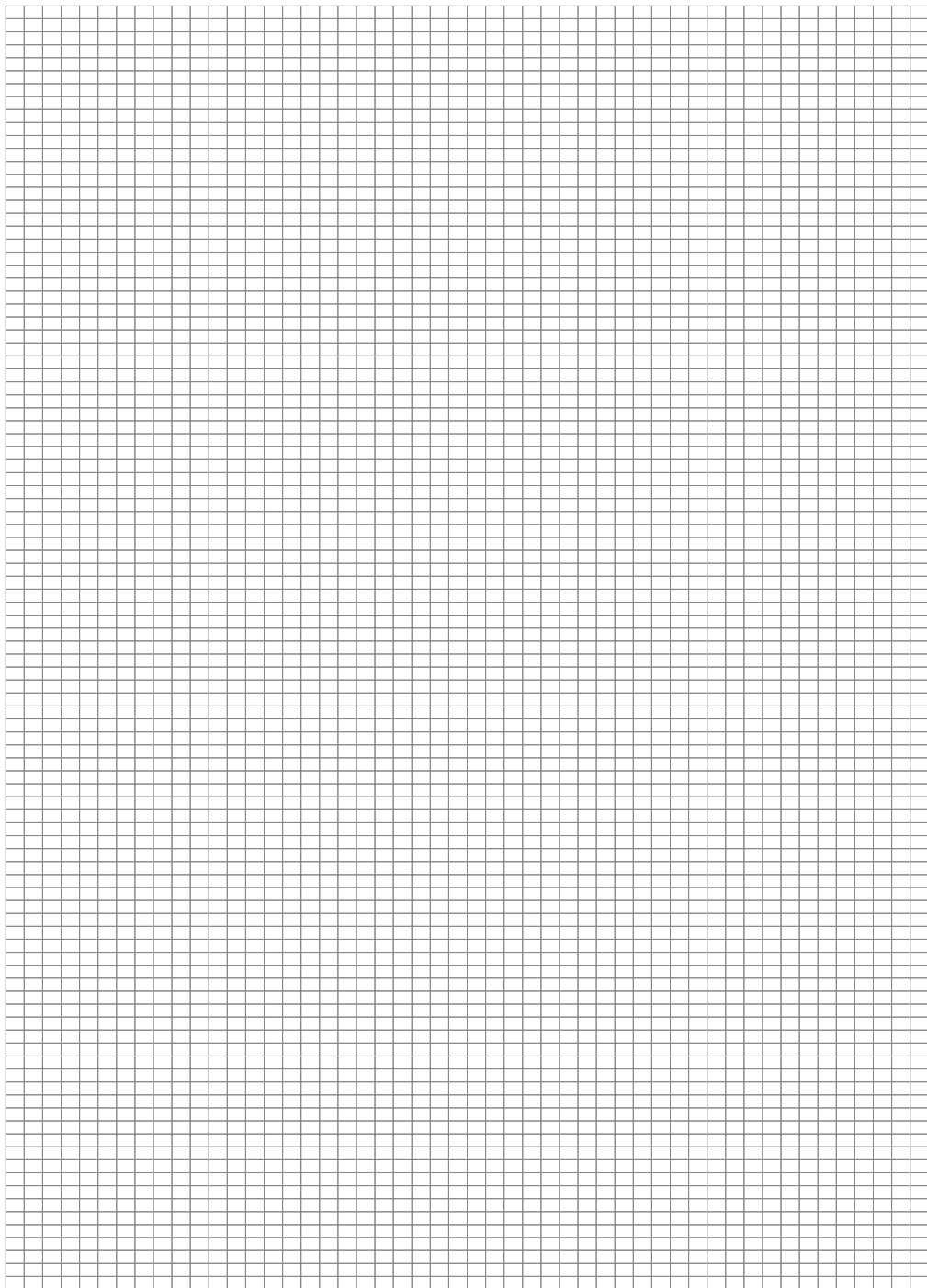

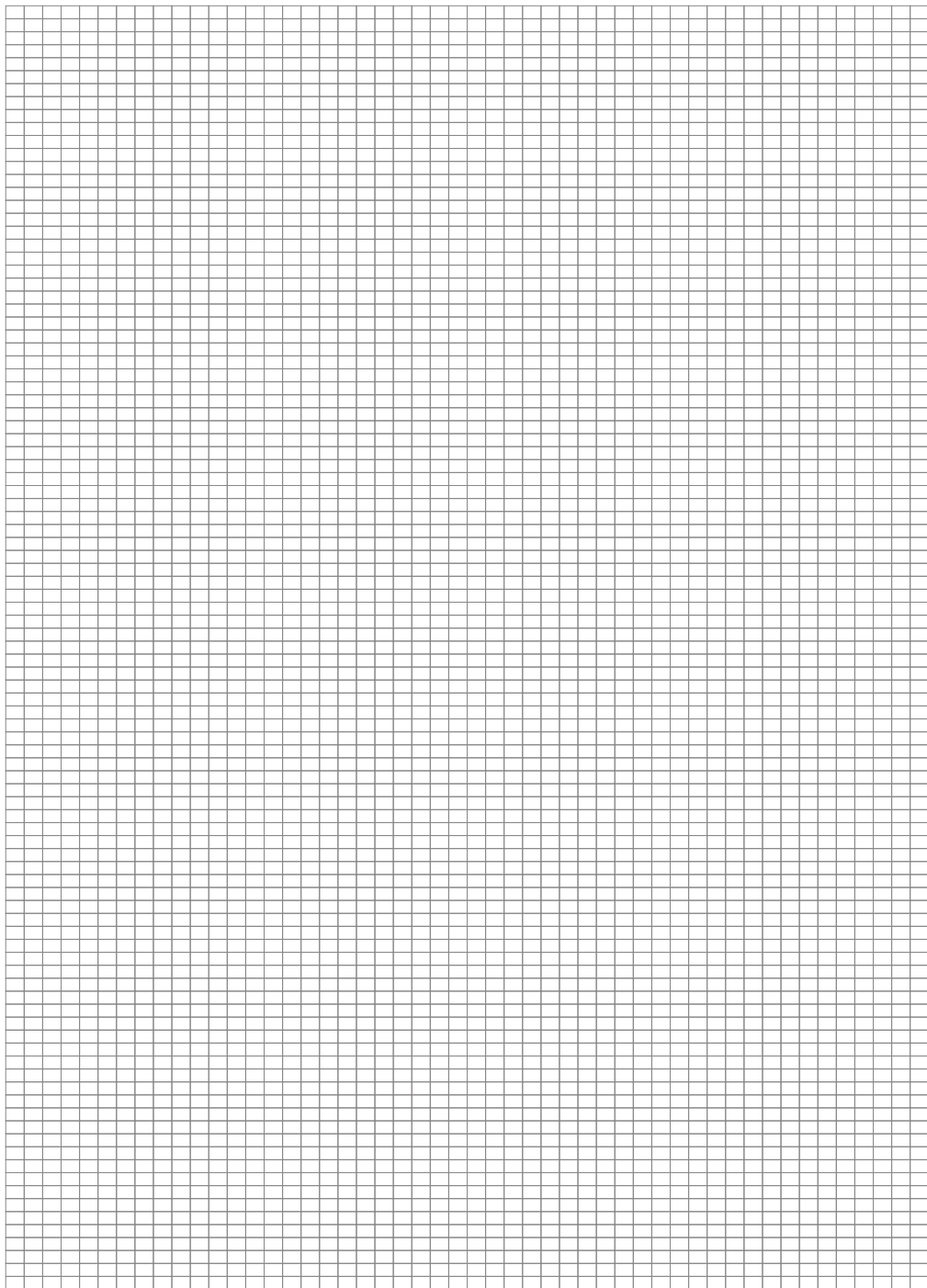





www.eneko.com.tr

İSTANBUL

 Cevizli District, Zuhul Avenue, Fusun Street, Ritim Istanbul
A5 Block Floor: 25 No: 137, 34846 Maltepe/Istanbul - TURKEY

 +90 216 455 29 60 /+90 216 455 29 61

 +90 216 455 29 62

 satis@eneko.com.tr

İZMİR

 10049 Street No: 4 I.A.O.S.B.
Cigli/Izmir - TURKEY

 +90 232 328 20 80

 +90 232 328 20 22

 info@eneko.com.tr